



Operating Instructions

SGA2

OP 350
Version: 1.5
Date: 11.2025
Owner: SWE
Language : EN

Operating Instructions Gas Manifolds and Gas Panels **SGA2**

Panels	Semi-Auto manifold	Manual manifold
Brass chromed		
SGA2 P V 300-15-25	SGA2 SA 300-12-15	SGA2 M 300-15-25
SGA2 P 300-15-25	SGA2 SA V 300-12-15	
SGA2 P 300-50-100	SGA2 SA 300-50-100	
Stainless steel		
SGA2 P.S 300-3-5	SGA2 SA.S V 300-10-15	
SGA2 P.S V 300-15-25	SGA2 SA.S 300-25-40	
SGA2 P.S V 300-25-40		
SGA2 P.S 30-3-5 NH3		

Warning

To preserve the quality of our product throughout its usage in the best safety conditions, please read this manual carefully and strictly follow the instructions that it contains. Non-compliance with these instructions or modification of the product may result in serious accidents or bodily injuries. AIR LIQUIDE shall not be held responsible in case of non approved usage of the product. Air Liquide reserves the right to make all necessary modifications to the specifications described hereafter without notice.

CONTENTS

1 GENERAL INFORMATIONS	3
1.1 Safety	3
1.2 Flow restrictor installation	4
1.3 Air Liquide Commitments	5
1.4 Designation and marking	6
2 FIELD OF USE AND CHARACTERISTICS	7
2.1 Functions	7
2.2 Technical characteristics	8
2.3 Gas Compatibility	8
3. INSTALLATION	10
3.1 Installation of the gas manifold	10
3.2 Assembly of a compression fitting	10
4. ACTIVATION	11
4.1 Washing of the network and seal checks	11
4.2 Activation	11
5.USAGE	13
5.1 Use	13
5.2 Cylinders or Bundles change	13
5.3 After use	14
6 MAINTENANCE	15
6.1 Troubleshooting	15
6.2 Maintenance	16
6.3 Spare Parts	17
6.4 Decommissioning - Disposal	20
7 NOMENCLATURE AND DRAWINGS	21
7.1 Nomenclature	21
7.2 Drawing of a gas Panel	22
7.3 Drawing of a manual Manifold	23
7.4 Drawing of a gas Manifold	24
7.5 Connections	25
7.6 Extension ramps	26
7.7 P&ID	26
8 FLOW CURVES	28

1 GENERAL INFORMATIONS

1.1 Safety

First of all, it is **ESSENTIAL** to read and respect the safety instructions described in the document “General Safety Instructions” delivered with the product.

NEVER use the SGA2 equipment with a different gas than the one specified in the “gas compatibility tables”.

This product meets the safety requirements of the laws in force and has been designed and tested to guarantee safety.

The product is available in two versions :

- Gas Panel : for one inlet (one pressure reducer)
- Gas Manifold : for two cylinders sources inlet (two pressure reducers)

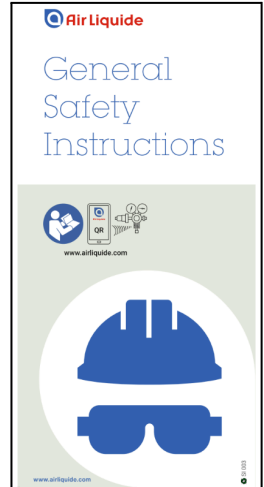





It is **ESSENTIAL** to follow conscientiously the instructions described in this manual to install, use and perform maintenance tasks safely.

We therefore disclaim any liability for damages caused by non-compliance with the instructions herein and by anything else not contemplated herein.



Personal Protective Equipment:

PROTECTIVE GLOVES /CHEMICAL-RESISTANT GLOVES	
PROTECTIVE SHOES	

WORK CLOTHES	
PROTECTIVE GOGGLES	
HEAD PROTECTION	
BREATHING APPARATUS DEPENDENT ON AIR CIRCULATION	
EAR PROTECTION	

1.2 Flow restrictor installation

A calibrated orifice (flow restrictor) with a diameter of **2 mm**, provided in a plastic bag for all models, must be mounted inside the outlet fitting before installation.

It aims at limiting the flow rate at a nominal value defined by the reducers outlet pressure P2 defined for each SGA2 model.

For helium and hydrogen, a specific fitting with integrated calibrated orifice of **1 mm** must be installed.

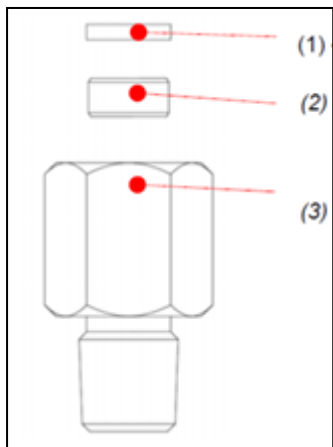

Legend:

- (1): Flat seal PTFCE
- (2): Calibrated orifice
- (3): Outlet fitting female

Integrated OC 1 mm for He and H₂:



The SGA2 is equipped with a pressure relief valve (PRV) for the discharge of overpressure; the sole purpose of this valve is to protect the regulators but not the pipeline or the elements downstream of the manifold; the relief valve vent should be channeled for the combustibles and neutral gas if the location is insufficiently ventilated.

It is the user's responsibility to protect its installation, taking into consideration the maximum operating pressure, by installing a **pressure safety valve** (PSV) gauged with respect to maximum pressure risks and maximum theoretical flow.

	Seat diameter (Equivalent diameter in mm)	Max theoretical nitrogen flow		Measured N ₂ flow
		200 bar	300 bar	300 bar
SGA2*	1,35	174 Nm ³ /h	232 Nm ³ /h	106 Nm ³ /h

* For use with helium or hydrogen, the SGA2 calibrated orifice (d=1mm) must be used.

1.3 Air Liquide Commitments

Air Liquide certifies that this equipment is manufactured, tested and controlled, in accordance with the technical specifications described in the AIR LIQUIDE specifications.

In addition to technical specifications, a degreasing process consistent with oxygen service is applied.

It is the responsibility of the end user to ensure that such equipment is installed and used in accordance with the regulations.

Directive 2014/68/CE : Pressurized equipment (PED).

Technical requirements of Article 4§3 indicates that Pressure equipment and assemblies below or equal to the limits set out in points (a), (b) and (c) of paragraph 1 and in paragraph 2 respectively shall be designed and manufactured in accordance with the sound engineering practice of a Member State in order to ensure safe use.

Without prejudice to other applicable Union harmonization legislation providing for its affixing, such equipment or assemblies shall not bear the CE marking referred to in Article 18.

By design, these equipment may integrate pressure relief valves or burst disks. In this case, those ones shall neither be CE marked according to paragraph 2 of annex II.

In all other cases, pressure relief valves and burst disks shall be CE marked.

Directive 2014/34/UE ATEX :

The equipment are not in the scope defined in points a), b) et c) of the article of the ATEX Directive: consequently, they shall not bear the CE marking.

The equipment is not capable of causing an explosion through their own potential sources of ignition: then, they can be installed in ATEX zone 1 or 2, as far as respecting up to date regulations, rules, operating instructions, in accordance with the sound engineering practice that are followed during installation and use.

Reminder: it belongs to the end user to define the ATEX zone.

REACH regulation (EC) n°1907/2006

The equipment is made of brass parts, essentially the body, which is a copper alloy with a lead content between 1% and 4% w/w.

As requested by art.33 of REACH Regulation (Registration, Evaluation and Authorisation of Chemicals) and with reference to current list of SVHC (substances of very high concern) available on ECHA website, we inform that lead may be present in a concentration above 0,1% w/w in our products made of brass.

Lead inclusion in the SVHC list in June 2018 does not modify the use conditions described in operating instructions.

Lead will not be released to the surrounding environment or the gas used during normal use.

After product end of life, the pressure reducers must be scrapped by an authorized metal recycler.

Cleaning :

Each equipment is subject to a grease removal and high quality cleaning to preserve the purity of gas in the equipment as well as for use with oxygen for compatible equipment. A suitable packaging protects the equipment from exterior pollutants during storage and transport.

Take care to avoid polluting the equipment during the installation.

Plant inspections :

Each equipment is inspected and has undergone a sealing test (Helium test) before packing.

A pressure test is performed with 200 bar or 300 bar helium gas.

After 12 hours, the leakage rate must be less than 1.10^{-9} scm³/s.

Leakage rate internal/external : $<10^{-7}$ mbar.l/s helium.

Warranty :

The warranty period of this equipment supplied by Air Liquide is one year, (6 months if the equipment is used with corrosive gas), with spare parts and labor and does not include packing and transport fees. Excluded from warranty: seals and relief valves.

These components are subject to natural wear.

Warranty is not valid on deterioration which results from wrong or poor use, from use of spare parts which are not marked Air Liquide, or if operating instructions are not respected.

For more information, refer to the general sales conditions of Air Liquide

1.4 Designation and marking

A plate is affixed to the system's metal structure of the SGA2, providing the following information:

Model : Change over manifold or Panel

AL Designation, example: SGA2 SA 300-10-15

Maximum working pressure : P1=310 bar

Maximum outlet pressure : P2

Nominal flow rate: Q_{max}= xx Nm³/h

NORMATIVE REFERENTIAL :

ISO 7291 Gas welding equipment – Pressure regulators for manifold systems used in welding, cutting and allied processes up to 30 MPa (300 bar).

2 FIELD OF USE AND CHARACTERISTICS

2.1 Functions

Single stage gas manifolds SGA2 are used to :

- connect one or several cylinders or bundles at the head of the pipeline
- reduce the pressure of a gas packaged under high pressure (200 or 300 bar at 15°C) in a cylinder or a bundle.

The Panel SGA2 P aims at adjusting an outlet pressure with a single gas source.

The manual manifold SGA2 M allows adjusting the operating pressure, with two gas sources with a manual change.

Given that there is only one outlet, only the regulator with the highest set pressure release.

The semi automatic Manifold SGA2 SA provides a fixed outlet pressure, with a slight gap between the two sides when the semi-automatic change between the two gas sources occurs.

The user has only to operate the switch for cylinders/bundles, once the handwheel is turned on the new operating source side to restore the normal outlet pressure (hence the phrase "semi-automatic with manual reset" used for these manifolds).

If a stable pressure is required on the customer application, it is necessary to install a second-stage on line regulator, just after the manifold.

	Model	Adjustable Pressure	Connection cylinder/bundle	Continuity of supply	Cylinder change without stop
Panel	SGA2 P	Yes	1 X 1	No	No
Semi-Auto Manifold	SGA2 SA	No	2 X 1	Yes	Yes
Manual manifold	SGA2 M	Yes	2 X 1	No	No

2.2 Technical characteristics

Operating temperature : -20 °C to +50 °C

Fittings :

- Gas inlet HP on the valve block : M16x 1,336 SI F
- Gas outlet toward user application : **G 3/8" F**
- Relief valve vent outlet : G 1/4" F
- Vent of the block valve purge : G 1/4" F
- Connections for pressure transmitter : G 1/4" F
- Outlet toward extension ramps: G 1/4" F

2.3 Gas Compatibility

IMPERATIVE : check the gas compatibility of this equipment by referring to the "Gas Compatibility Table".

The SGA2 single-stage manifolds are mainly designed for the implementation of pure gases and mixtures with purity (< N60), including ALPHAGAZ 1 & 2.

- Air gases (O₂, N₂, Air, Ar, He...)
- Carbon dioxide and Ar/CO₂ mixtures
- Hydrogen (H₂),
- Nitrous oxide (N₂O) and oxidizing mixtures

In case of doubt about the use of the equipment, its compatibility with the gas or a new application, please consult Air Liquide.

Panel for low pressure liquid gas	material	Pmax	NH ₃ (8.4 bar)*	SO ₂ (3.4 bar)*	H ₂ S (18.4 bar)*
SGA2 P.S 30-3-5-NH3	stainless steel	30 bar	Y	Y	Y

* Cylinder pressure at 20°C.

NB: for corrosive gas, add a purging system with inert gas

Manual Manifold :

Panels	material	N ₂	CO ₂	CO	Air*	O ₂	N ₂ O	H ₂	C _n H _m **
SGA2 M 300-15-25	Chromed brass	Y	Y	N	Y	Y	Y	Y	N

Panels:

Panels	material	N ₂	CO ₂	CO	Air*	O ₂	N ₂ O	H ₂	C _n H _m **
SGA2 P 300-15-25	Chromed brass	Y	Y	N	Y	Y	Y	Y	N
SGA2 P V 300-15-25	Chromed brass	Y	N	N	Y	Y	N	Y	Y
SGA2 P 300-50-100	Chromed brass	Y	Y	N	Y	Y	Y	Y	N
SGA2 P.S 300-3-5	stainless steel	Y	Y	Y	Y	N	N	Y	N
SGA2 P.S V 300-15-25	stainless steel	Y	N	N	Y	N	N	Y	Y
SGA2 P.S 300-25-40	stainless steel	Y	Y	Y	Y	N	N	Y	N

Semi automatic Manifolds :

Panels	material	N ₂	CO ₂	CO	Air*	O ₂	N ₂ O	H ₂	C _n H _m **
SGA2 SA 300-12-15	Chromed brass	Y	Y	N	Y	Y	Y	Y	N
SGA2 SA V 300-12-15	Chromed brass	Y	N	N	Y	Y	N	Y	Y
SGA2 SA 300-50-100	Chromed brass	Y	Y	N	Y	Y	Y	Y	N
SGA2 SA.S V 300-10-15	stainless steel	Y	N	N	Y	N	N	Y	Y
SGA2 SA.S 300-25-40	stainless steel	Y	Y	Y	Y	N	N	Y	N

*Air: compressed air not breathable

**C_nH_m : propane (6bar), propylene (8bar), ethylene (70 bar), methane (200 bar)

The Panels in stainless steel are usable with corrosive gas.

3. INSTALLATION

3.1 Installation of the gas manifold

Set the manifold (see drawing).

The surface on which the support plate will be mounted, must be flat. Any deformation of the chassis during the installation could affect the proper operation of the equipment.

If needed, mount and connect the extension ramps (see Options).

Fix the racks (in case of cylinder use).

Attach the panels "Cylinders/bundles change procedure" and the "Safety precautions" corresponding to the gas used. They have to be visible and in close range.

Install the intermediary connections that correspond to the expected use.

Put the cylinders in the racks with the safety chain.

Install the flexible hoses or the pigtailed following the indications written in the user manual.

Attach the safety cables. Use the holes for that purpose on the support plate. In case of bundles, attach the anti-flapping cable to a solid anchor plate fixed to the ground (ref AL: 190489).

In case of SGA2 used with hydrogen or Helium, install at the outlet the calibrated orifice adapted to the gas used and delivered with the equipment.

Connect the outlet of the support plate to the pipe network.

Install a shut-off valve between the support plate and the pipeline, (see options).

If necessary, collect the purges and the relief valve (particularly for the combustible gases) and channel them separately to a safe area (tube 10mm ext. and h > 2,5m).

In case of combustible gases, connect the plate to the ground and ensure the electrical continuity between the different components.

3.2 Assembly of a compression fitting

Check dimensions and respect material compatibility between connection and pipe : Connection and pipe must always be made from the same material, example: Stainless steel connection for stainless steel pipe <Rockwell hardness B90 (exception : brass connection with copper pipe).

Connector pre-assembled by hand.

- After cutting, deburring and blowing on the tube (use preferably a tube cutter), pre-assemble the nut and the ferrules, following the order and the direction indicated in the figure.
- Introduce the tube inside the connector up to the stop limit on the body.

- Clamp the nut completely by hand.
- Complete the clamping using a wrench by turning the nut a 1^{1/4} turn.

4. ACTIVATION

4.1 Washing of the network and seal checks

Even though the different components of the equipment have been carefully checked in the factory, it is nevertheless necessary to make a verification of the sealing of the mounted assembly before commissioning:

Once installed and before use the distribution network and the manifold system must be vented of any air contained therein, in order to prevent the formation of explosive mixtures within the mains and the equipment.

WARNING :

- Purge the equipment with inert gas or nitrogen (never use compressed air).
- For the tightness check, use only products without any grease or lubricants.
- Never use the purge valves of the manifold to purge the pipe downstream the manifold (high risk of polluting the pressure reducers).

4.2 Activation

First stage: Flexible hoses purging.

Initial state :

- Closed HP shut-off valves (2) and purge valves (3).
- Closed outlet shut-off valve.
- Purge all flexible hoses or pigtails, by at least 3 compressions-reductions cycles, ie: open the cylinder/bundle valves (1) and close it before reaching the pressure of the cylinder (high pressure gauge (5)), wait 1 minute, slowly open the purge valve (3) and then close it before falling to atmospheric pressure.

Second stage: function control

Initial state :

Closed cylinder/bundle valves

- Closed HP shut-off valves (2) and purge valves (3).
- Closed outlet shut-off valve.

Indicate the main gas source to use first by using the lever (4). (case of the SGA2 SA)

- On the right: lever to the right

- On the left: lever to the left

- Open slowly all cylinder/bundle valves (1).
- Open slowly the HP shut-off valves (2) on the main gas source.
- Note the outlet pressure of the low pressure gauge (6).

In the case of adjustable models, adjust the pressure with the handwheel

- Slowly open the HP shut-off valve (2) on the 2nd gas source (In case of SGA2 and M manifolds).
- Open slowly the outlet valve.
- Let the gas flow normally through the manifold and purge all pipes.
- Limit the outlet flow during the filling of the pipe network to avoid vibrations.

If necessary, adjust the outlet pressure (only for SGA2 M and P))

❑ **3rd stage: verification of the automatic switchover** (In case of Semi-Automatic SGA2 manifolds only)

- Close the cylinder/bundle valves of the main gas source in service, the high pressure gauge (5) decreases.
- When the HP pressure falls below 2 times the working pressure, the gas source in reserve will enter gradually in service.
- The LP pressure gauge (6) indicates the pressure of the gas source in reserve.
- Change the position of the lever, the initial outlet pressure is now restored. The previous gas source in reserve becomes the "main" gas source in service.
- Repeat in reverse the operation, to check that the automatic switchover works well in both directions.

Remark : if during the switchover, the pressure difference "deltaP" is too disturbing for the user, it is recommended to install a second stage pressure regulator at the outlet.

❑ **4th stage: setting in flow**

- The tested equipment is now ready to use.
- Slowly open the shut-off valve at the outlet.
- In the case of the SGA2 SA, when the gas source in service is empty, the switchover to the gas source in reserve will be automatic.
- It will be sufficient to switch over the position of the lever so that the gas source initially in reserve will be in service, at the required working pressure.
- Then, change the empty cylinders or bundles which will be automatically in reserve.
- The gas source in service is indicated by the position of the lever.

- The arrow on the lever indicates the “main” gas source.

➤ **Always open the cylinder (or bundle) valves slowly and gradually.**

Do not open or close purge valves and shut-off valves with the flow valves while the cylinder is open. Opening or closing of the purgers and shut-off valves with the flow valves while the cylinder is open may damage them.

If there is a leak, proceed as follows :

- depressurize the installation ;
- make sure that all seals (if necessary) are made with the adequate material and that they are indeed present ;
- re-tighten the fittings

WARNING : Never handle a fitting under gas pressure. Always turn valves and levers GRADUALLY and SLOWLY.

Repeat the procedure to recheck the seals.

In the case of a manifold for the inlet with two groups of cylinders, repeat the operation for the secondary gas source (with the lever in the opposite position).

If the leak still exists, repeat the previous operations and replace the seals.

The perfect tightness of the manifold is essential for its commissioning.

If the manifold and/or the distribution network still have leaks, the manifold must not be put into service.

Once the previous conditions checked, the manifold is ready for its commissioning.

5.USAGE

5.1 Use

Adjust the outlet pressure according to your need with the handwheel (except SGA2 SA).

5.2 Cylinders or Bundles change

Identify the empty cylinders or bundles.

1- Push the handle (4) (for semi-automatic gas manifold only):

- Leftward : if empty cylinders are on the left.
- Rightward: if empty cylinders are on the right.

Substitution of the empty cylinders/bundles.

2- Close the High Pressure shut off valve (2) (empty side) on the gas manifold or on the stanchion (for connections with more than 2 bundles).

3- Close the cylinder or bundle valves (1).

4- Slowly open the purge valve (3) and release the pressure, then close the valve. The pressure gauge must indicate 0 bar.

5- Disconnect the flexible hoses or the pigtailed from the cylinders or the bundles.

6- Replace the empty cylinders or bundles and safely store.

7- Verify the cleanliness of the cylinders' or bundles' valve outlet.

8- Connect the flexible hoses or the pigtailed after changing the seals. (- O-rings : Hand-tightens - other seals : wrench tight) -Do not forget to remount the safety cable.

9- Slowly open the cylinder or bundle valves (1) and close them again before reaching the maximum pressure.

10- Wait about 1 minute.

11- Slowly open the purge valve (3) and close it again before reaching the atmospheric pressure.

12- Start twice this cycle from point (9) to (11). (4 to 6 times in case of pure gases).

13- Slowly open the cylinder or bundle valves (1) (at least 2 turns)

14- Slowly open the High Pressure shut off valve (2).

Do not allow a flexible hose to rub against the ground or a wall. Fix the chain holding the cylinders in the racks. In the case of bundles, make sure that they are on a horizontal surface in order to guarantee their stability. All flexible hoses or pigtailed must be connected and safety cables hooked up before opening the cylinders or bundles valves.

5.3 After use

- Close all shut-off valves and cylinder (or bundle) valves (1).
- Open the purge valves (3), purge the installation and the flexible hoses (or pigtailed). The pressure gauges shall indicate "0".
- Close the purge valves again. (3).
- Dismantle and store carefully the flexible hoses and the pigtailed. Store safely from dust and of moisture.
- Screw the blind plugs on the "High Pressure" inlet ports with an allen wrench (dimension : 1/4" (6,35mm)).

Manifold system external cleaning

Any equipment cleaning must be carried out without disassembling or operating the shut-off, measurement and adjustment devices. Neutral products must be used for cleaning, which must in no way interact with the equipment and with the materials with which it is made.

6 MAINTENANCE

6.1 Troubleshooting

The following table shows a list of simple issues, their possible causes and remedies that may be put into practice by the manifold system user. Never try to fix a component.

PROBLEM	CAUSE	REMEDY
Connection between flexible hoses and valve block of the manifold impossible.	The fittings do not match.	Ensure the fittings are compatible with the type of gas used, inlet and/or outlet.
	Damaged fittings.	Replace the fittings.
Insufficient gas flow rate.	Limited flow section through a valve.	Open the valves completely.
	Cylinder discharged or empty.	Replace the cylinder.
	Cylinder valve not operating.	Replace the cylinder/bundle.
	Undersized equipment.	Consult Air Liquide.
	Equipment in output not operational.	Replace the equipment.
The gas source in reserve drains without being used (SGA2 manifold only).	Excessive instant consumption.	Replace with a source capable of delivering a higher flow rate.
	Leak outwards.	Check the seals.
	Leakage at the main valve of the regulator.	Replace the pressure reducer.
Gas leaks out from the safety valve.	Leak from reducer shutter	Replace the regulator.
	Defective safety valve.	Replace the relief valve.

Frosting	The used gas is argon (Ar), carbon dioxide (CO2) or nitrous oxide (N2O).	Use a heater at the inlet.
The outlet pressure decreases	Excessively high flow rate.	Comply with the reducers' nominal flow rate. Limit the flow using a suitable valve or calibrated orifice.
Vibrations	Excessively high flow rate Presence of a valve with rapid opening on the outlet pipe. Undersized manifold.	Respect the regulator flow. Limit the flow by using a valve or a calibrated orifice.

6.2 Maintenance

The maintenance of the manifold system must be carried out by qualified personnel.

In order to assure the correct operation of the manifold system and the distribution system in which the manifold system is installed over time it is necessary to carry out the inspection and/or replacement operations set out in the following table.

It can be performed annually by Air Liquide under a maintenance contract (SERVIGAZ). The period should not exceed 5 years.

V: to verify C: to change		Regularly			1 /year (1)	5 /years (1)
		a	b	c	d	e
operations:						
	Purge valve	V		V		V
	Stop valve HP	V		V	V	V
	Manometer HP	V	V	V		note (2)
	Pressure regulator	V	V	V	V	V
	Manometer BP	V	V	V		note (2)
	Relief valve	V		V		V

Description of maintenance operations in the table :

- a) Check of gas leak outside (leak test using a *Mille-Bulles™* or equivalent)
- b) Correct operation
- c) General appearance including marking
- d) Seal check
- e) Complete replacement

After each maintenance work, perform the steps planned in the chapter “Activation”.

6.3 Spare Parts

To see the complete list of available spare parts, consult Air Liquide.

Use only original parts and do not modify the equipment.

Components of the SGA2 that can be replaced :



Step 0: system's depressurization

Ensure the valves of the cylinders or cylinder packs are closed.

Close the flow valve to the downstream network.

Depressurize the system with purge valves.

Ensure there is no gas under pressure by ensuring the high pressure gauge shows zero pressure.

Slowly unscrew the fittings between the valves of the cylinders or cylinder pack and each connected hose at the inlet of the valve blocks.

If necessary, depressurize the gas network downstream the SGA2.

Step 1: disassembly of a part to be replaced

1°) Release the 3-piece nuts that link the elements together using two open-end wrenches.

- Positioning the first wrench allows to hold the fixed part to the body (a),
- Unscrew the nut with the second wrench and previously check the direction (not to the right)



A: part to keep fixed

B: nut to unscrew

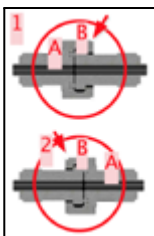

2°) With an allen wrench ($\frac{1}{4}$ '-6,35mm) slightly unscrew the 4 screws involved in order to allow each component to have mobility and lateral freedom.



Hold each element to replace after the loosening.
Remove the 2 screws to be removed.

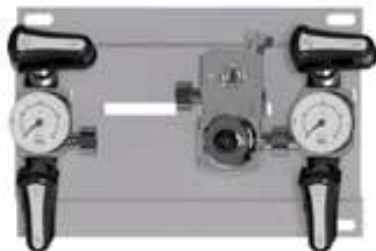

Step 2 : reassembly of a spare part

- Position the new element. Make sure that the seals used are correctly positioned and undamaged.
- Lightly screw by hand the two screws of the component in order to ensure mobility on the plate before the tightening of the 3-piece nuts. Tighten the nuts by hand
- Tighten with a dynamometric spanner (tightening torque **25 Nm**), while holding the other side with the second wrench.
- Tighten all screws that fix the elements to the support plate.

Step 3 : Pressurization and seal check

1°) Pressurization

Reconnect the links (flexible hoses or pigtails) between the SGA2 manifold and the gas sources and previously check that the seals are undamaged and free from impurities.

Purge the residual gas by opening the purge valves (the pressure gauges shall indicate "0"), then close the purge valves.

Close the gas outlet on the operating side, by closing all shut-off valves downstream the SGA2.

Open the cylinder valve until no flow noise is heard.

Close the cylinder valve.

2°) Seal check

Observe the pressure on the manometer and check that it does not drop.

With a leak detection liquid type *Mille-Bulles™* or an equivalent one, check that there are no leaks in the connections.

If you detect a leak, replace the seals/O-rings.

If there is no leak, the SGA2 can be put in service by following the operating instructions of the user manual.

6.4 Decommissioning - Disposal

Operations to be carried out prior to decommissioning the manifold system

The following operations are to be carried out prior to decommissioning the manifold system:

- Ensure the valves of the cylinders or cylinder packs are closed.
- Completely open the outlet valve, shut-off valves and the purge valves.
- Open all points of use in order to depressurize the downstream network of the manifold.
- Ensure the high pressure gauge shows zero pressure.
- Slowly unscrew the fittings between the valves of the cylinders or cylinder pack and each connected hose.

Operations for decommissioning the manifold system

The operations for decommissioning the manifold system are as follows :

- Disconnect the hoses from the inlet fittings of the valve block of the manifold system.
- Disconnect the discharge pipe from the safety valve outlet.
- Disconnect the discharge pipe from the outlet of every purge valve of the valve block
- Disconnect the outlet of the manifold
- Unscrew the nuts fastening the manifold system plate to the supporting wall taking care to support the manifold system.
- Once the manifold system is detached from the installation it must be disposed in accordance with local laws in force.

Disposal :

In accordance with Directive EU 2018/851 on waste, the equipment holder ensures that, where recovery in accordance with Article 10 is not undertaken, waste undergoes safe disposal operations which meet the provisions of Article 13 on the protection of human health and the environment.

The holder shall take measures to promote high quality recycling and, to this end, shall set up separate collections of waste where technically, environmentally and economically practicable and appropriate to meet the necessary quality standards for the relevant recycling sectors.

7 NOMENCLATURE AND DRAWINGS

7.1 Nomenclature

Benchmark	Description of the components
1	Purge valve
2	High pressure inlet valve
3	Adjustable regulator for the panel and the manual manifold
4	Gas cylinder 200 bar or 300 bar
5	Connection between the source and the SGA2: flexible hose or pigtail in stainless steel
6	Pressure relief valve of the manifold
7	Fixed reducer of the semi-automatic manifold
8	Handwheel left side (L) /right side (R)

7.2 Drawing of a gas Panel

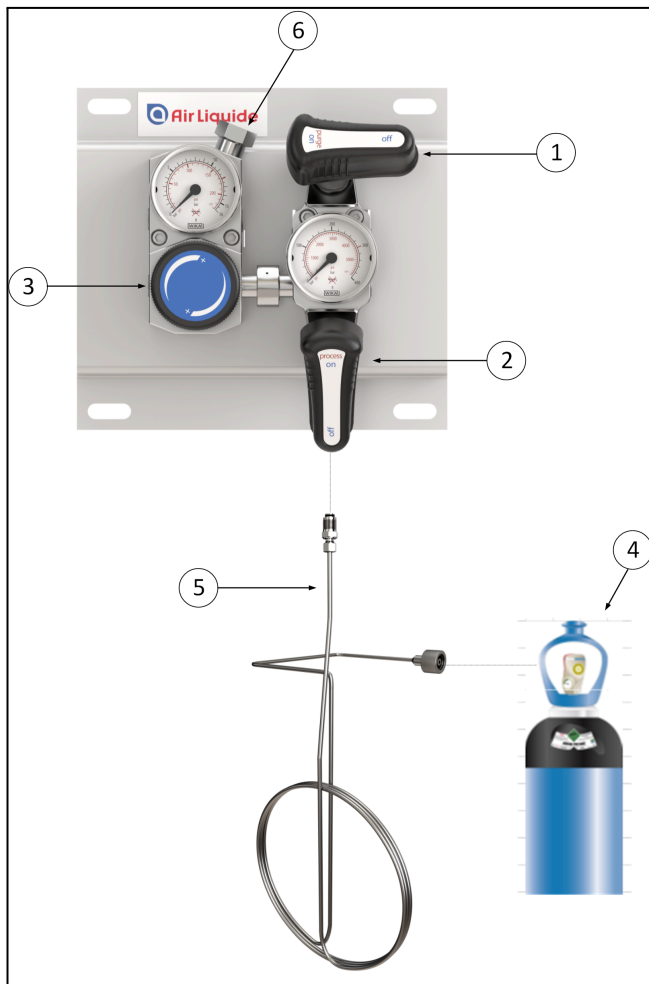

7.3 Drawing of a manual Manifold

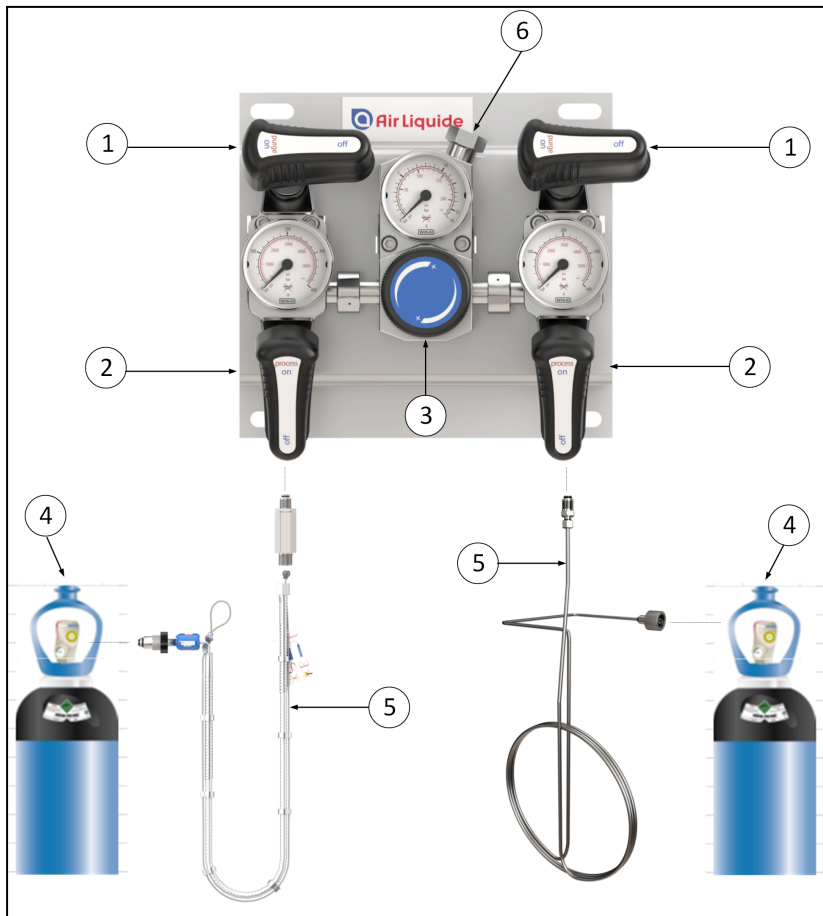

7.4 Drawing of a gas Manifold

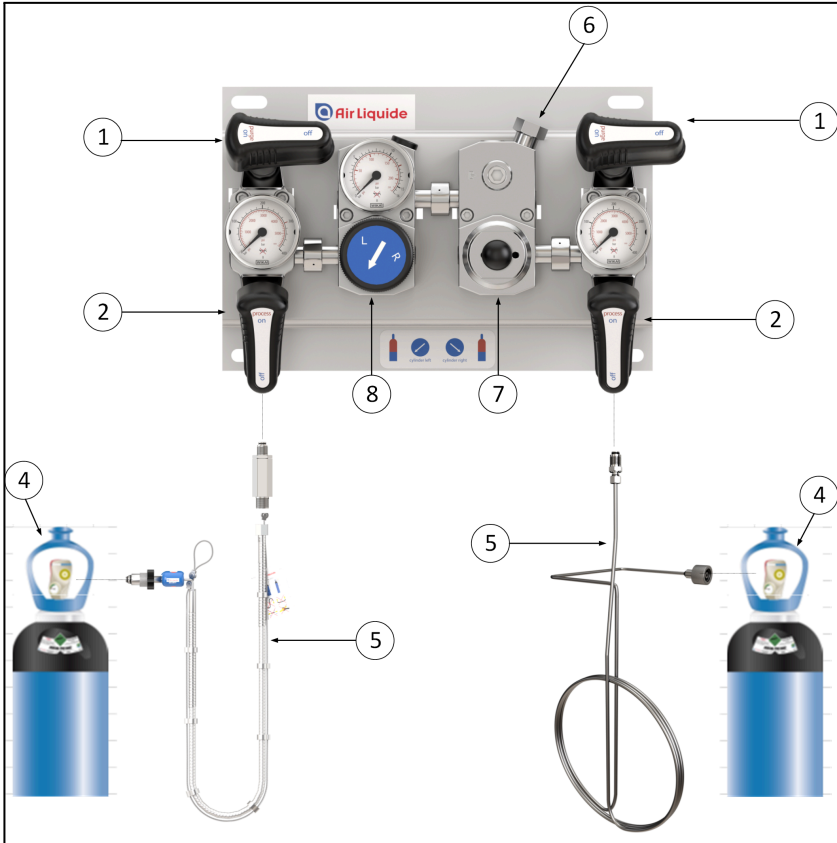

7.5 Connections

Symbols engraved on equipments :

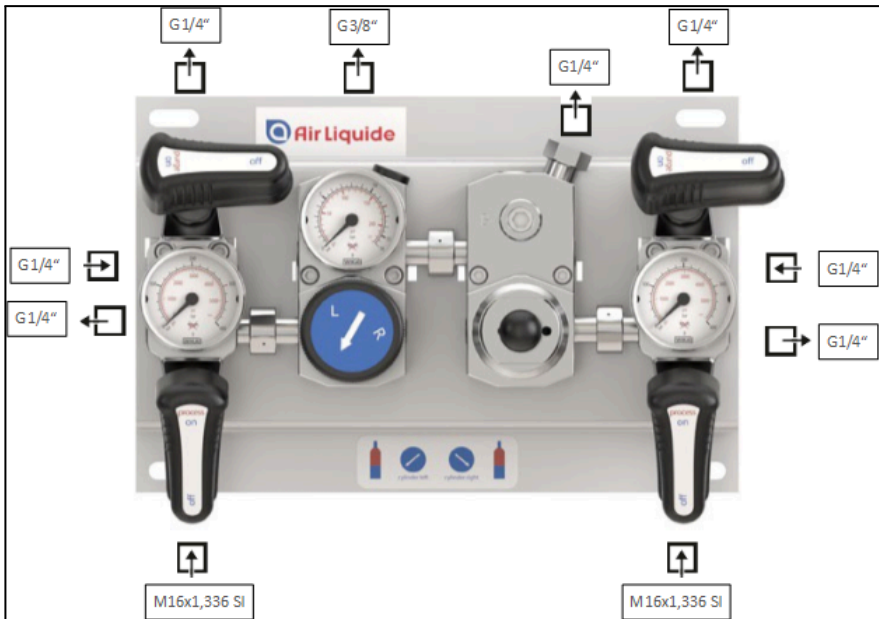
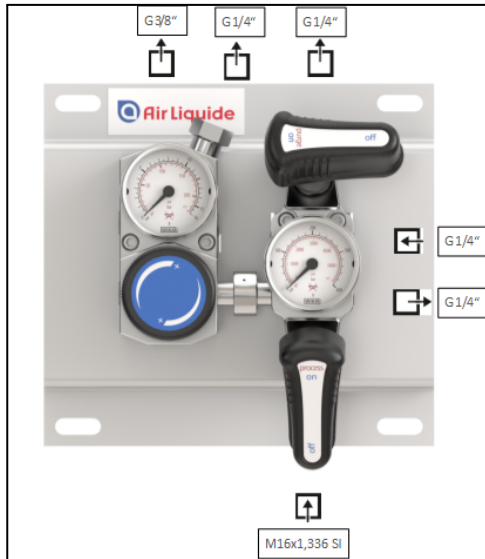
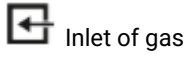

7.6 Extension ramps

The extension ramps allow to connect a cylinder or a further bundle with any inlet valve block of the SGA2.

For a gas manifold, it is possible to connect: 2 x 2 cylinders/bundles.



7.7 P&ID

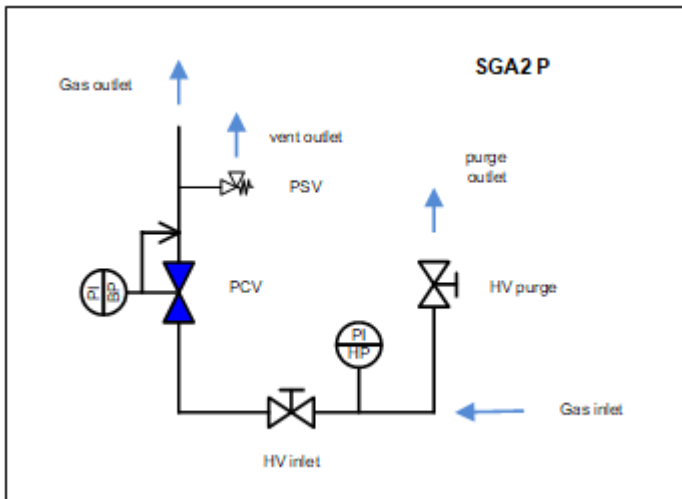

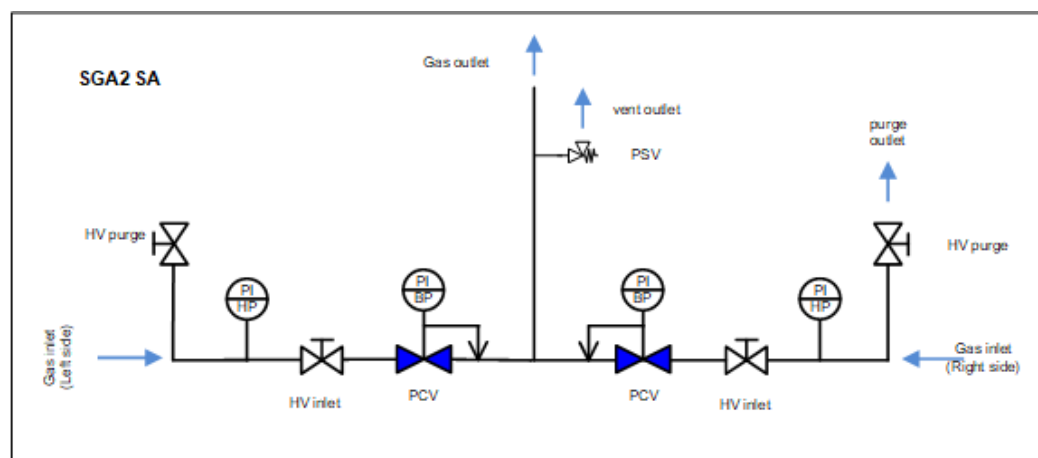
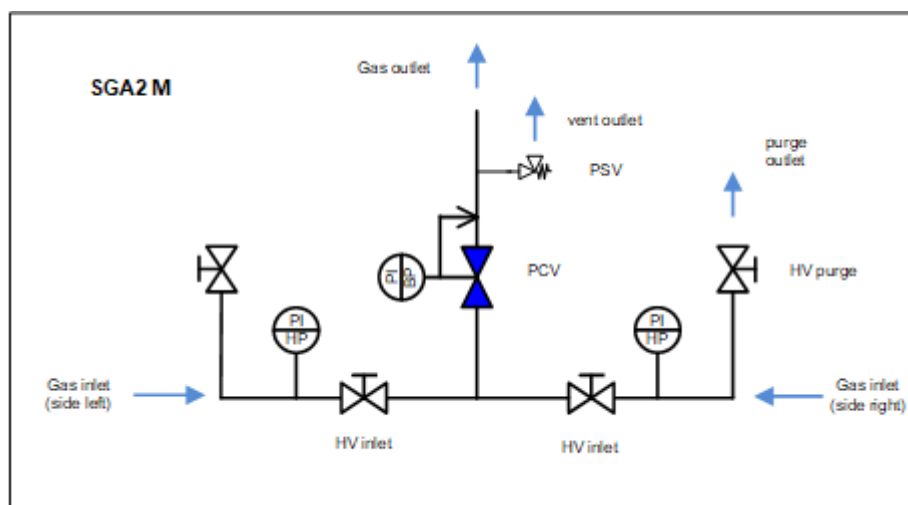

NB : For the SGA2 SA, outlet pressures are preset (not adjustable).

8 FLOW CURVES

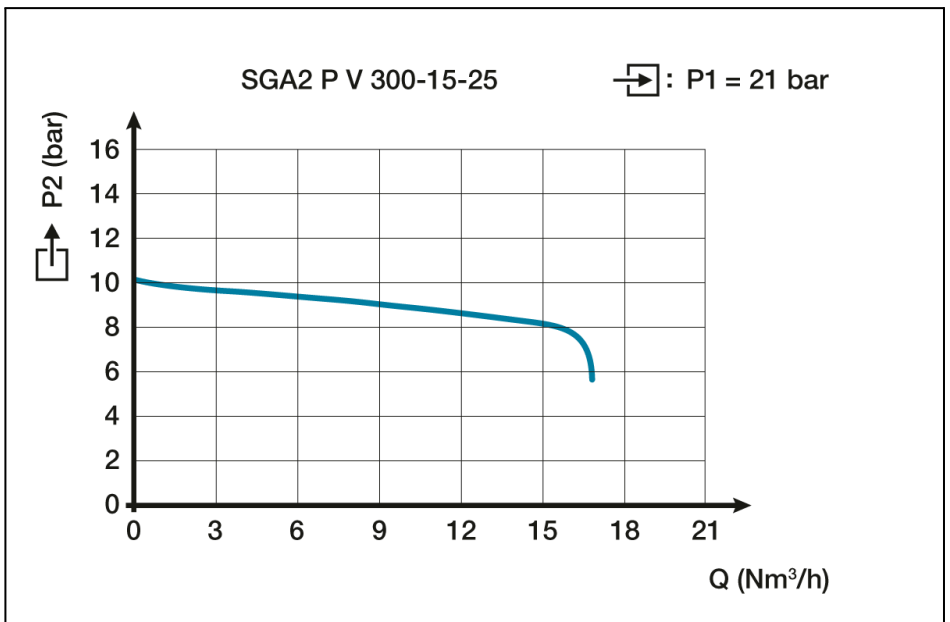
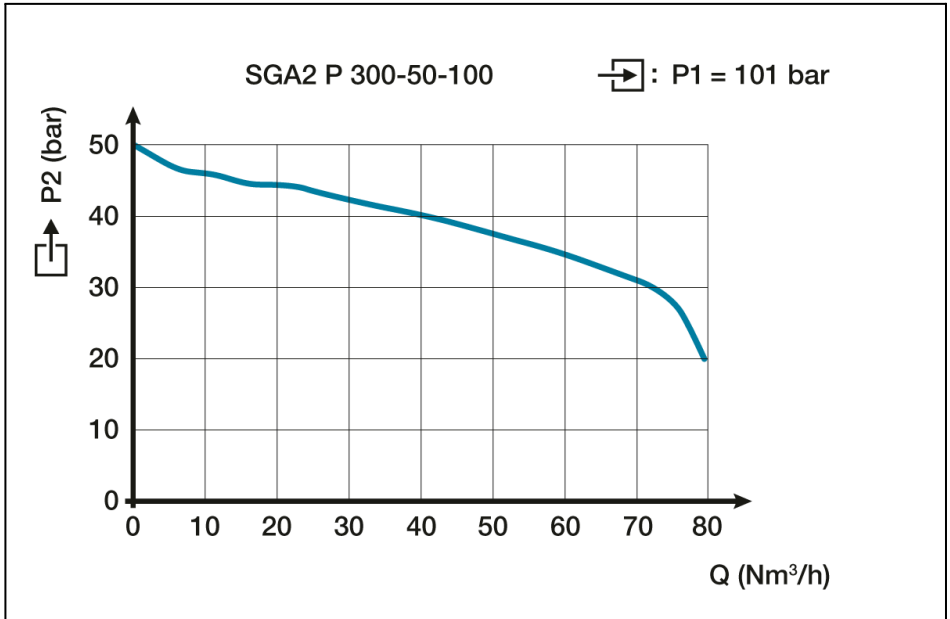

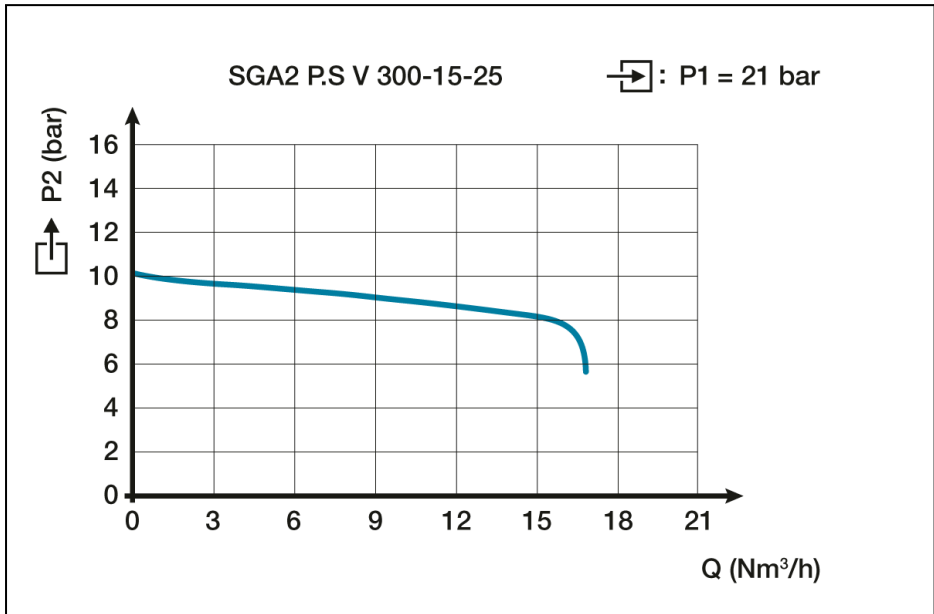
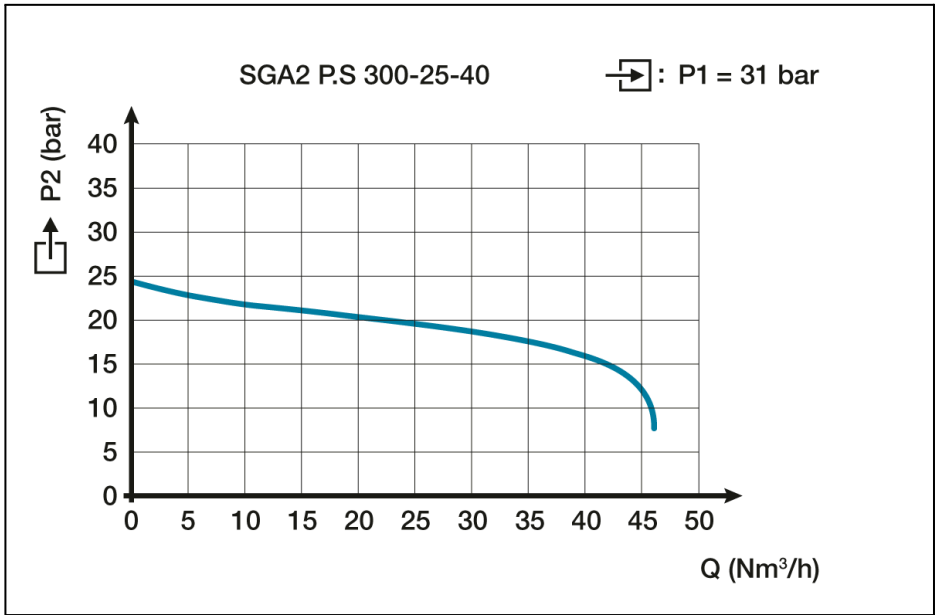

SGA2 SA.S 300-25-40

→: P1 = 31 bar

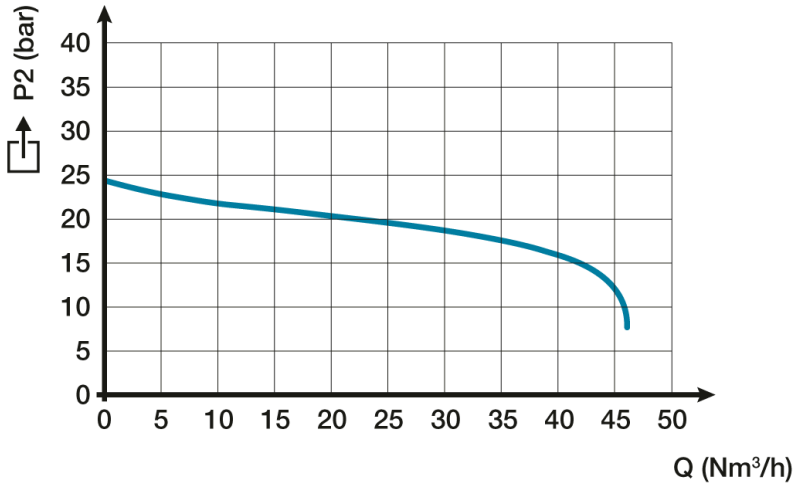

SGA2 SA.S V 300-10-15

→: P1 = 21 bar

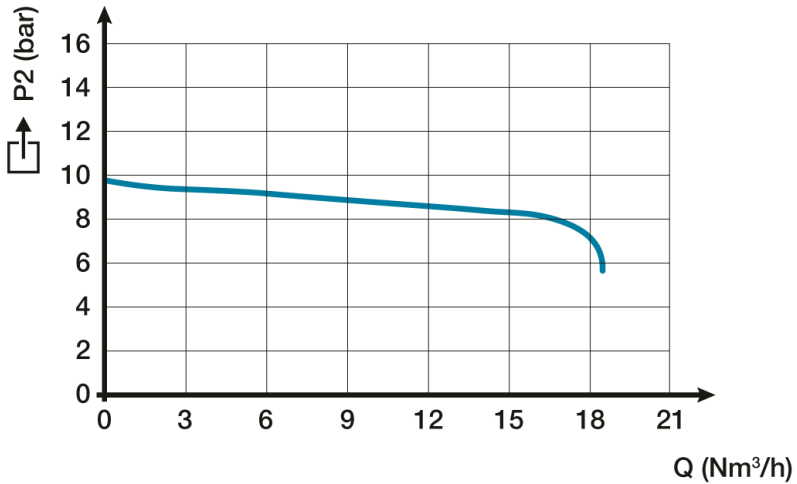

SGA2 M 300-15-25

→: P1 = 31 bar

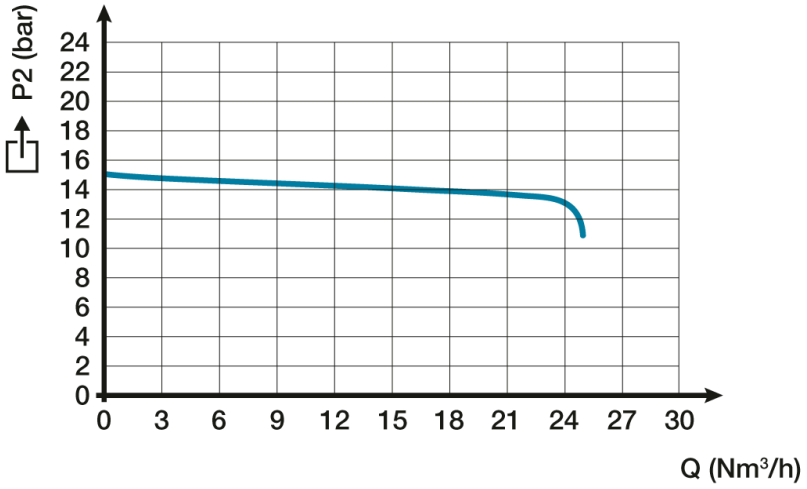

To contact us :

Air Liquide France Industries

Customer care - Phone. **09 70 25 00 00**

Email : **contact.alfi@airliquide.com**

Customer area : **<https://fr.airliquide.com/>**



Air Liquide France Industrie - Société Anonyme au capital de 72.267.600 Euros - Siège social : 6 rue Cognacq-Jay, 75007 Paris - RCS Paris 314 119 504.