

Manifolds

Steel / brass

Operating manual



Manifolds steel /brass

Content

Page

1	Preliminary notes – Warranty and liability	4
2	Usage	5
2.1	Function	5
2.2	Type of Gas	5
2.3	Devices for requiring acceptance plants	5
2.4	General conditions for operation, transport and storage	5
2.5	Connections	5
2.6	Intended use	5
2.7	Guidelines	6
3	Safety instructions	7
3.1	The handling of gases	7
3.2	Gas-specific design	7
3.3	Duties of the operator	7
3.4	Duties of the personnel	7
3.5	General regulations and notes	7
3.6	The resistance of the materials	7
3.7	Purging – leakage of harmful gases and vapors	7
3.8	Dangers due to pressure energy	7
3.9	Special hazards due to leakage	7
3.10	Dangers due to electrical energy	8
3.11	Cleaning the gas appliances and disposal of residues	8
3.12	Notes on special types of gas	8
4	Marking	8
4.1	Name plate	8
4.2	CE marking	8
5	Flow scheme	9
6	Installation	10
6.1	Assembly	10
7	Operation	11
7.1	Commissioning	11
7.2	Changeover and cylinder change	11
7.3	Decommissioning	11
8	Operation of the gas shortage warning device	12
8.1	General operation of the gas shortage warning device	12
8.2	Notes on pressure transmitter or cylinder scale	12
9	Instructions for operation and maintenance	13
9.1	Troubleshooting	13
9.2	Maintenance	14
9.3	Repairs	15
9.4	Disposal and recycling	15
10	Gas compatibility	16

SGA2 SA
SGA2 SA V
SGA2 SA.S
SGA2 SA.S V

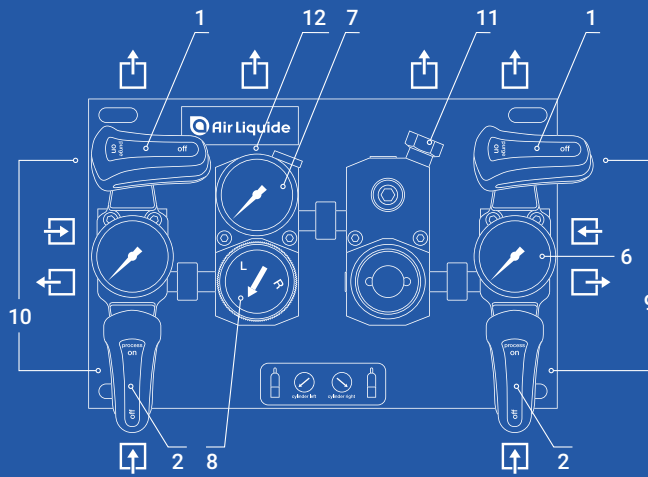

SGA2 P
SGA2 P V
SGA2 P.S
SGA2 P.S V

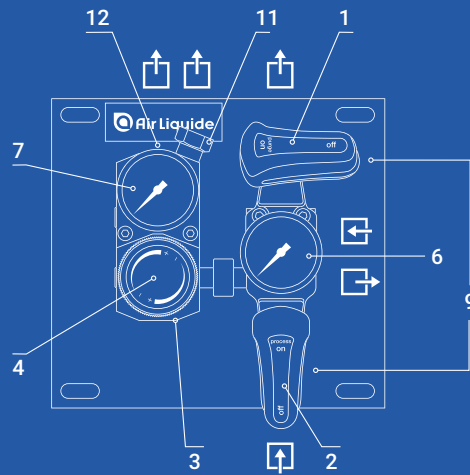

SGA2 M
SGA2 M V

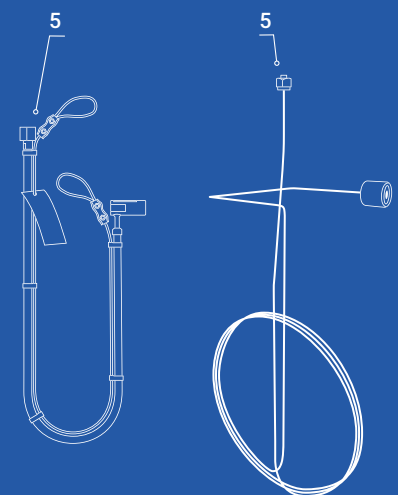
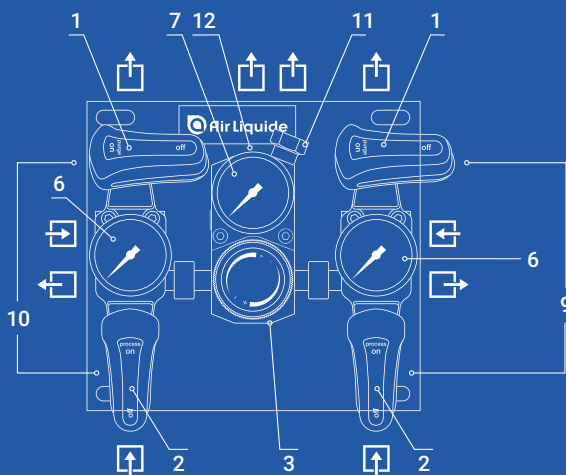

- | | |
|---|---|
| 1. Purge Valve | 8. Active side switch |
| 2. Process Gas Valve | 9. Block valve right |
| 3. Regulator | 10. Block valve left |
| 4. Regulator | 11. Safety relief valve |
| 5. Connection pig tails / flexible hose | 12. Outlet process gas
(Use of orifice (according to type of gas)) |
| 6. Back pressure manometer gauge | |
| 7. Pre pressure manometer gauge | |

1 Preliminary notes

According to the legislator, the operator is responsible for the safety and health of his employees. He is obliged to prepare a risk analysis of his company. He must also provide employees with the necessary work equipment to prevent hazards from arising. In addition, must regularly monitor and document the safety-related systems document this.

This operating manual is intended to help that a small part of these requirements can be met.

Our pressure control panels comply with the actual rules of regulation and are design according to the state of the art.

These devices are precision instruments of the highest quality. Through the use of selected materials, high surface quality and tightness it's possible to control pressure and flow of pure gases with consistent accuracy.

All steps – from conception, through production to final inspection – are subject to the strict criteria of our quality assurance according to DIN EN ISO 9001.

Each complete system and its individual parts are tested for function and tested with helium for leak tightness, thus guaranteeing the well-known quality.

Warranty and liability

Our "General Terms and Conditions of Sale and Terms of Delivery" apply. These are available to the operator at the latest upon conclusion of the contract. Warranty and liability claims for personal injury and property damage are excluded if they are attributable to one or more of the following causes:

- Improper use of the equipment.
- Improper installation, commissioning, operation and maintenance of the pressure and maintenance of the equipment.
- Operation of the pressure equipment with defective safety devices or improperly installed or or non-functioning safety and protective devices.
- Failure to observe the instructions in the operating manual regarding transport, storage, assembly, commissioning, operation, maintenance and set-up of the pressure equipment.
- Unauthorized structural modifications to the pressure equipment.
- Unauthorized alteration of the cylinder connections for the use of other types of gas, exceeding the permissible inlet pressure permissible inlet pressures, the use of foreign or non-original seals.
- Inadequate monitoring of equipment, screwed connections and sealing parts that are subject to wear.
- Improperly performed repairs.
- Exceeding or falling below the temperature range specified in the data sheet during operation or during storage.
- Catastrophic events due to the effects of foreign bodies and higher force majeure.

The warranty period of this fitting supplied by AIR LIQUIDE is one year, including spare parts and repair, excluding postage and packing costs.

Excluded from the warranty are gaskets, these parts are subject to natural wear.

No warranty is given for the following reasons:

- unsuitable and improper use
- improperly carried out repairs
- installation of non-original spare parts
- failure to follow these operating instructions.



For further information please refer to the General Terms and Conditions of AIR LIQUIDE.

2 Usage

2.1 Function

Pressure manifolds are used as central supply system for technical and high-purity gases to supply one or more points of use. The points of use are supplied via a piping system connected downstream the manifold.

Pressure control panels are available in various designs:

1. One-sided for connection of one or more cylinders. These stations are used wherever a working process can be interrupted due to a gas shortage or where the gas consumption is so low that a cylinder change can be calculated.
2. Manual changeover for connection of 2x1 or several cylinders stored on two sides. The area of application of this design is everywhere, where a process cannot be interrupted due to a lack of gas, but a manual process cannot be interrupted due to lack of gas, but a manual changeover is possible (e. g. during normal working hours).
3. Automatic changeover for connection of 2x1 or more cylinders stored on two sides. If a working process runs for a longer period of time and cannot be interrupted due to lack of gas and a manual changeover is not possible in terms of time (e. g. outside working hours, at night or at the weekend), then the use of these stations is required.
4. All pressure control panels can be supplied with pressure transmitters. For flammable gases as Ex-version, also for Ex-zone 1+2 applicable. The cylinder pressure is measured in conjunction with a signal device which indicates the level of gas in the cylinder. If the pressure is below of a warning value, an alarm will be triggered.
5. Stations for oxygen, nitrous oxide and carbon dioxide can be supplied with gas heaters.
6. If larger quantities of gas are required, it is of course possible to use cylinder bundles, which can be connected via a high-pressure hose (please note the max. flow rate of the station).
7. Pressure control panels can be extended as required by retrofitting extension modules. The respective cylinder pressure (max. 200/300 bar at 20 °C) is adjusted by the pressure regulator to the desired outlet pressure. The exact parameters can be found from the data sheet or product catalog.
8. A line shut-off valve should be installed in the pipeline downstream of the battery pressure regulator. A protection against excess pressure of the main piping is mandatory, here we recommend the installation of a suitable safety valve. Options especially for the manifolds are listed in the data sheet under "Options".

2.2 Type of Gas

Depending on the version of the manifold, for high purity gases incl. 6.0. See gas compatibility table Chapter 10.

2.3 Devices for requiring acceptance plants

Details of required test certificates or certificates for materials, tightness, etc. must be known when the order is placed.

2.4 General conditions for operation, transport and storage

Ambient temperatures: -20°C to 50°C
Transport and storage: -20°C to 55°C
Atmospheric conditions:
rel. Humidity: 50 % at 40°C
90 % at 20°C

Environment: ambient air free of unusual quantities of dust, acids, corrosive gases or substances such as smoke, steam, oil vapor, etc.



Note: Use of pressure control panels unprotected outdoors will impair the quality of the gases and can endanger the functional safety.

Deviating conditions can be agreed between the manufacturer and user upon.

2.5 Connections

Input station:

More detailed information can be found in the corresponding product data sheet.

Output Station:

More detailed information can be found in the corresponding product data sheet.

Purge outlet:

More detailed information can be found in the corresponding product data sheet.

2.6 Intended use

The pressure device is intended exclusively for the pressure regulation of gaseous media from pressurized gas cylinders. Any other use or use beyond this is considered to be not in accordance with the intended use.

Intended use also includes

- observance of all instructions in the operating manual,
- observance of the inspection and maintenance work,
- observance of the type plate and the data sheet

2.7 Guidelines

2.7.1 Conformity

AIR LIQUIDE certifies that these equipment are in conformity with the technical specifications of AIR LIQUIDE, which have been manufactured, tested and inspected accordingly. The manifolds are suitable for use with oxygen, provided that the valve is specified for this purpose in chapter 10.

Please observe the relevant national and international laws, regulations, directives, standards, technical rules as well as the regulations and bulletins of employers' liability insurance association.

2.7.2 PED Directive 2014/68/EC: Pressurized equipment

The AIR LIQUIDE fittings with a nominal diameter <25 mm (e. g. pressure regulators, valves, filters, etc.) meet the requirements of Article 4, Paragraph 3 of the Directive 2014/68/EU and the provisions of the article. Therefore these devices do not bear a CE marking according to Article 18 of this Directive.

2.7.3 ATEX Directive 2014/34/EC

The cylinder pressure regulators are not in the scope defined in points a), b) et c) of the article of the ATEX Directive ; consequently, they shall not bear the CE marking.

The regulators are not capable of causing an explosion through their own potential sources of ignition: thus, they can be installed in ATEX zone 1 or 2, provided that up to date regulations, rules and operating instructions are observed accordingly during installation and operation. Reminder: it is the responsibility of the end user to define the ATEX zone.

2.7.4 REACH regulation (EC) n°1907/2006

The pressure reducers are made of brass parts, essentially the body, which is a copper alloy with a lead content between 1% and 4% w/w. As requested by art. 33 of REACH Regulation (Registration, Evaluation and Authorisation of Chemicals) and with reference to current list of SVHC (substances of very high concern) available on ECHA website, we inform that lead may be present in a concentration above 0,1% in our products made of brass.

Lead inclusion in the SVHC list in June 2018 does not modify the use conditions described in operating instructions.

Lead will not be released to the surrounding environment or the gas used during normal use. After product end of life, the pressure reducers must be scrapped by an authorized metal recycler.

2.7.5 FOOD regulation (EC) n°1935/2004

The AL equipment enhancing the term "FOOD" in their designation are specifically designed for use with food gases used for food and beverage applications. They are compliant with Regulation EC 1935/2004 which requires that packaging and articles intended to be in contact with foodstuffs are to be manufactured in compliance with good manufacturing practices and standard operating procedures.

Thus, under normal or foreseeable conditions of use, no transfer of contaminants, e. g. metal elements, to food in quantities that could endanger human health, modify food composition or deteriorate organoleptic characteristics is expected.

Nethertheless, the end-user must check the compliance with an eventual national regulation.

Articles for food usage has a Food logo marking. For traceability purposes, the batch number is written on each article and AL can perform a batch recall, as requested by its Quality.

2.7.6 Cleaning

Each equipment is subject to a grease removal and a high quality cleaning to preserve the purity of gas in the equipment as well as for use with oxygen for compatible equipment. A suitable packaging protects the equipment against exterior pollutants during storage and transport.

Take care to avoid polluting the equipment during installation.

2.7.7 Testing

Prior to packing, each valve is checked for function and for tightness.

3 Safety instructions

3.1 The handling of gases

The handling of technical and high-purity gases, in particular toxic (poisonous), flammable or fire-promoting gases, requires expert knowledge, the observance of these operating instructions and the existing regulations.

The training and regular safety instruction of the operating personnel on how to handle this equipment, with toxic (poisonous), flammable or fire-promoting gases and pressurized gas containers is mandatory. In case of improper handling and/or use of the equipment the equipment may result in danger for the operating personnel and other persons as well as damage to the system and the environment may occur.

These operating instructions must always be available to the operating personnel at all times.

3.2 Gas-specific design

The manifold may only be used for the specified gas type (see chapter 10). Alternating use for different gases and the attachment of adapters to the cylinder connection is not permitted. The selection of materials and gaskets is only related to the respective specified gas type.

3.3 Duties of the operator

The operator is obligated to only allow persons to work on the pressure device who

- are familiar with the basic regulations on work safety and accident prevention and
- have permanent access to these regulations,
- have read and understood the safety chapter and the warning notes in this operating manual. These employees are trained and instructed in order to be able to work on the pressure control panels.
- The safety-conscious work of the personnel is checked at regular intervals.
- The responsibilities of the personnel for assembly, commissioning and operating must be clearly defined.
- Personnel to be trained may only work on the pressure device under the supervision of an experienced supervisor.
- All safety and danger notices must always be kept in a readable condition.
- The required personal protective gear must be provided by the operator.

3.4 Duties of the personnel

All persons who are assigned to work on the pressure equipment are obligated to read and understand the fundamental safety and accident prevention regulations and to familiarize themselves with the safety data sheet for the type of gas used.

3.5 General regulations and notes

The pressure control panels comply with the state of the art and the recognized rules of technology. The devices have been designed in accordance with the PED Article 4, Paragraph 3, and are manufactured in accordance with good engineering. Without the approval of the manufacturer no modifications shall be made.

- Smoking or flames (e. g. candles) in the vicinity of your gas supply is strictly prohibited! Fire and explosion hazard!
- Do not use in ambient temperatures below -20 °C and above +50 °C, do not use for gases in the liquid phase.
- Use only for the marked pressures.

3.6 The resistance of the materials

The resistance of the materials is only ensured with dry gas and dry flushed piping and fittings. Incorrect assembly, leaking screw connections or improper purging can lead to a limitation of the service life.

3.7 Purging – leakage of harmful gases and vapors

When purging the system, care must be taken to ensure that the gas can be discharged or disposal of the gas must be ensured. This also applies to the outlet of the relief valve on the pressure regulator.

When safety devices are open or in the event of a malfunction harmful gases and vapors may escape. Ensure sufficient ventilation or extraction.

3.8 Dangers due to pressure energy

Depressurize piping sections before starting repair work. Check or even replace flexible hose at appropriate intervals, even if no safety-relevant defects are apparent.

External influences such as high temperatures, heat radiation, impact and the like, pressurized gas cylinders or pressurized system parts can become very hot or burst. Take appropriate precautions and safety measures.

3.9 Special hazards due to leakage

Due to the use of very hazardous, hazardous or less hazardous gases, leakages of equipment may result in danger to life of the user.

Therefore, an operating instruction according to § 20 GefStoffV, an actual EU safety data sheet according to § 14 GefStoffV and a tremcard with instructions for the physician in a suitable place.

Operators must be aware of the particular hazards of the gas and of possible personal and other protective measures. be pointed out.

4 Marking

3.10 Dangers due to electrical energy

Work on electrical components, display and control units (e. g. ALMS) may only be carried out by a qualified electrician.

Check the electrical equipment of the plant regularly. Loose connections and damaged cables must be immediately repaired or replaced.

The control cabinet or the electrical assemblies must always be locked at all times. Access is only permitted to authorized personnel with a key or tool.

If it is necessary to work on live parts, a second person must be called to switch off the main switch if necessary.

3.11 Cleaning the gas appliances and disposal of residues

Used equipment or equipment which is going through a maintenance check must be purged with inert gas (nitrogen, argon). Take care of solid gas residues in an appropriate manner. In particular, do not contaminate with oily rags or lubricants. Do not clean with solvents.

3.12 Notes on special types of gas

All parts that come into contact with oxygen must be kept free of oil and grease. Only use lubricants with special oxygen approval.

4.1 Name plate

A name plate with following information is located on the base plate of the manifold:

Manufacturer, date of manufacture, type designation, approved prepressure pressure (P1), unit-specific backpressure or mean closing pressure (P2), maximum flow rate and part number.

The serial number is printed as a device-specific identifier on a separate label in barcode 128 and in plain text.

4.2 CE marking

Since the station has been designed according to "good engineering practice" in accordance with Article 4, Para. 3, the station must not be CE marked. The marking of the manufacturer is affixed to the nameplate.

5 Flow scheme

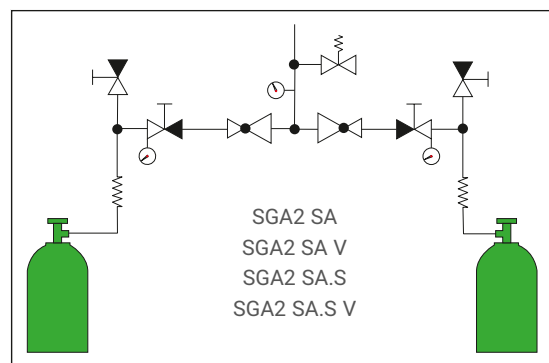
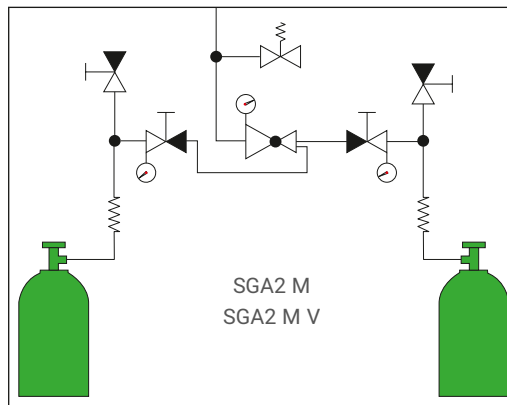
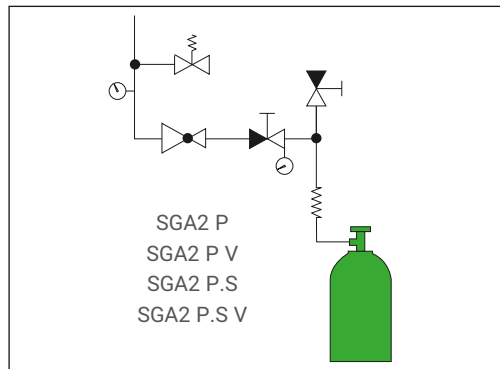

6 Installation

6.1 Assembly

- 6.1.1 Assembly may only be carried out by persons who are trained, experienced in the field of application (gas installations) and have been instructed in safety technology. The trainings and instructions must be carried out in regular intervals.
- 6.1.2 The pressure manifolds shall be supplied pre-assembled as far as possible. Check scope of delivery in accordance with the datasheet. Check on the basis of the type plate whether the station is suitable for the intended use (pressure, gas type, material).
- 6.1.3 Determine the dimensions of the drill holes according to the data sheet and fasten the base plate with appropriate screws.
- 6.1.4 The Cylinder brackets must be fixed on a Wall or similar. The support must be sufficient to prevent the Cylinder from falling down. When doing this the outer edges of the base plate should be vertical and approx. 3/4 of the cylinder height (for a cylinder height of 1500 mm, this is approx. 1100 mm) as horizontal orientation.
- 6.1.5 Hose lines / spiral tubes (5) via adapter / check valve or check valve with filter (antiflapping). First screw the adapter / check valve into the station inlet first.

 **The tool must only be applied to the narrow hexagonal.**

Then mount the hose line / spiral pipe on the check valve while holding it against the fitting body with a second wrench.

- 6.1.6 Check connection threads and connection surfaces of the cylinder valves and the gaskets for proper condition and fit (see Fig.8.10 / 8.11). Mount Flexible hoses / pigtails with hand connection (O-ring seal) without tools on the cylinder valve. Before connecting the flexible hose / pigtail, briefly open the cylinder valve once and then close it again, to blow out any dirt particles that may be present. Do not stand in front of the outlet opening of the of the valve (7) and make sure that no danger arises from the escaping gas. Good ventilation must be provided. Do not blow out flammable, corrosive, toxic and irritant gases.
- 6.1.7 At the outlet of the pressure regulator (12), the orifice plate included in the scope of delivery or optionally supplied must be inserted or mounted, depending on the type of gas. Adapt the outlet to the pipeline by using a compression fitting. Shortly after the outlet of the pressure regulator (12), a main line shut-off valve and, if necessary, a safety valve should be installed in the pipeline.
- 6.1.8 When toxic or flammable gases are used, safe discharge of the purge gas must be ensured. The exhaust gas pipes must be connected to the outlet connection of the blow-off valve on the pressure regulator (3 or 8) and to the purging valves (1) by using compression fittings.
- 6.1.9 After successful installation, the system must be purged with dry inert gas of suitable quality (e.g. nitrogen). All detachable connections must be leak tight. The tightness test must be certified and checked repeatedly at regular intervals.



Abb. 8.10 300 bar



Abb. 8.11 200 bar

7 Operation

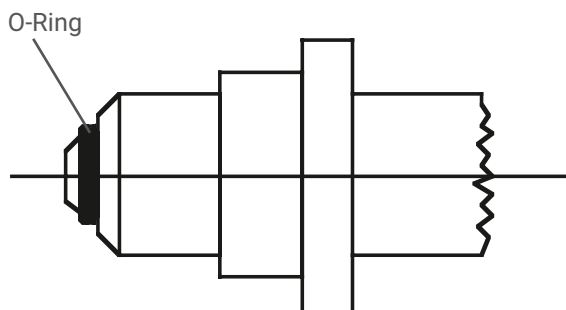
7.1 Commissioning

- 7.1.1 The manifold has been mounted according to chapter 6 and checked for possible leakages. The piping system mounted behind the manifold is filled with inert gas of the appropriate gas quality clean and dry and checked for any leakages.
- 7.1.2 Close all shut-off valves (1+2) and line valve (option). Unscrew the adjusting handle of the pressure regulator (3). The regulator spring is relaxed (not with semi-automatic versions).
- 7.1.3 Place full cylinders in front of the cylinder bracket and secure it with the strap or chain against falling over. Remove the protective cap of the cylinder. Check the valve thread, connection surface and seals. Check that flexible hoses and pigtailed (5) are not damaged. Replace damaged or worn seals. Only connect cylinders with the same permissible filling pressures (applies only to manifolds with multiple cylinders).
- 7.1.4 Screw the union nut of the flexible hose / pigtail (5) by hand to the sampling valve of the cylinder.
- 7.1.5 Slowly open the cylinder valve and close it again (in the case of multiple cylinders manifolds, open and close all bottle valves). Check connection at the cylinder valve for tightness.
- 7.1.6 Slowly open and close purge valve (1) (for two-sided stations, open and close purging valves on both sides). Repeat procedure 7.1.5 to 7.1.6 at least 5 times.
- 7.1.7 Slowly open cylinder valve(s).
- 7.1.8 Slowly open the service gas valve (2). For manifolds with manual changeover only the service gas valve (2) of the side that is to go into operation, keep the other side closed. For stations with semi-automatic changeover the arrow in the handwheel of the changeover controller (8) points to the side from which the sample is to be taken.
- 7.1.9 Set the pressure regulator (3) to the desired outlet pressure by turning the handle clockwise until the desired outlet pressure can be seen on the pressure gauge (7) (not applicable for SA/SA.S version). If necessary, open the main shut-off valve of the piping system (option) slowly so that the pressure in the downstream line builds up slowly.
- 7.1.10 Consumers can now be opened. Check pressure at pressure regulator (7) and readjust if necessary.

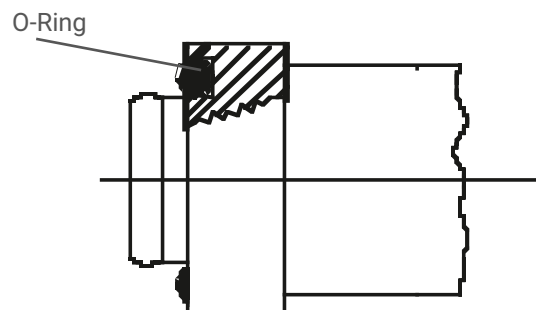
7.2 Changeover and cylinder change

- 7.2.1 Close the cylinder valve of the emptied gas cylinder.
- 7.2.2 Close the service gas valve (2). For two-sided manifolds with manual changeover, simultaneously open the service gas valve of the other side at the same time. For stations with semi-automatic changeover, turn the handwheel of the changeover regulator (8) to the other side. After that, close the service gas valve. Now the arrow in the handwheel of the changeover regulator (8) points to the side from which the gas is to be tapped.
- 7.2.3 Open the purge valve (1) on the side where the change of the cylinder needs to be performed (pressure relief). Close the purge valve and loosen the cylinder connection of the flexible hose / spiral tube (5) at the corresponding cylinder valve and connect the new cylinder (see also section 9.1 Commissioning).
- 7.2.4 Pressure build-up flushing as described in points 7.1.5 to 7.1.6 repeat at least 5 times.
- 7.2.5 Slowly open cylinder valve(s).
- 7.2.6 Slowly open service gas valve (2). For manifolds with manual changeover, open only the service gas valve (2) of the side that is to go into operation, keep the other side closed.
- 7.2.7 After the cylinder has been changed, the cylinder connections and the detachable connections must be checked for leak tightness.

7.3 Decommissioning

- 7.3.1 Close all valves (including cylinder valves).
- 7.3.2 Open and close purge valve(s) (1).
- 7.3.3 Depressurize battery pressure regulator (3) completely by removing gas from the end user so that the system is completely depressurized (upstream and downstream pressure gauges show 0 bar).
- 7.3.4 Unscrew the adjusting handle of the pressure regulator (3).

8 Operation of the gas shortage warning device

8.1 General operation of the gas shortage warning device

The monitoring system consists of the pressure transducers or a scales (ALMS Libra), the ALMS and the electrical signal cables, for combustible gases as a blue cable in intrinsically safe design.

The gas shortage warning is used to signal the emptying of cylinders and to inform the operating personnel of the impending changeover. This is done by means of an acoustic signal (buzzer) and an optical signal (light emitting diode) on the signaling device.

In the case of signaling devices that are connected to pressure pressure transmitters, the current content (pressure) is also directly displayed. These devices also have a second pre-alarm.

The acoustic message (buzzer) can be acknowledged on the signal device. However, the "Gas low" LED does not go out until a full cylinder is connected.

! The signal unit and the isolating switch must always be outside the hazardous areas.

The adapter(s) for the pressure transmitter can be mounted on the pressure manifold in different places. Locations, depending on the design of the pressure control panel.

An example is shown in the graphic below.

8.2 Notes on pressure transmitter or cylinder scale

The cylinder pressure at which a gas shortage signal is to be issued can be set on the monitoring system.

! For pressure control panels with automatic switchover, the switching point for the gas shortage signal must be higher than the changeover pressure of the manifold, otherwise no signal is given.

The electrical connection of the pressure transmitters or the cylinder scales and the monitoring system may only be done by respecting the operating instructions. Further information on this can be found in the operating instructions for the ALMS or ALMS Libra.

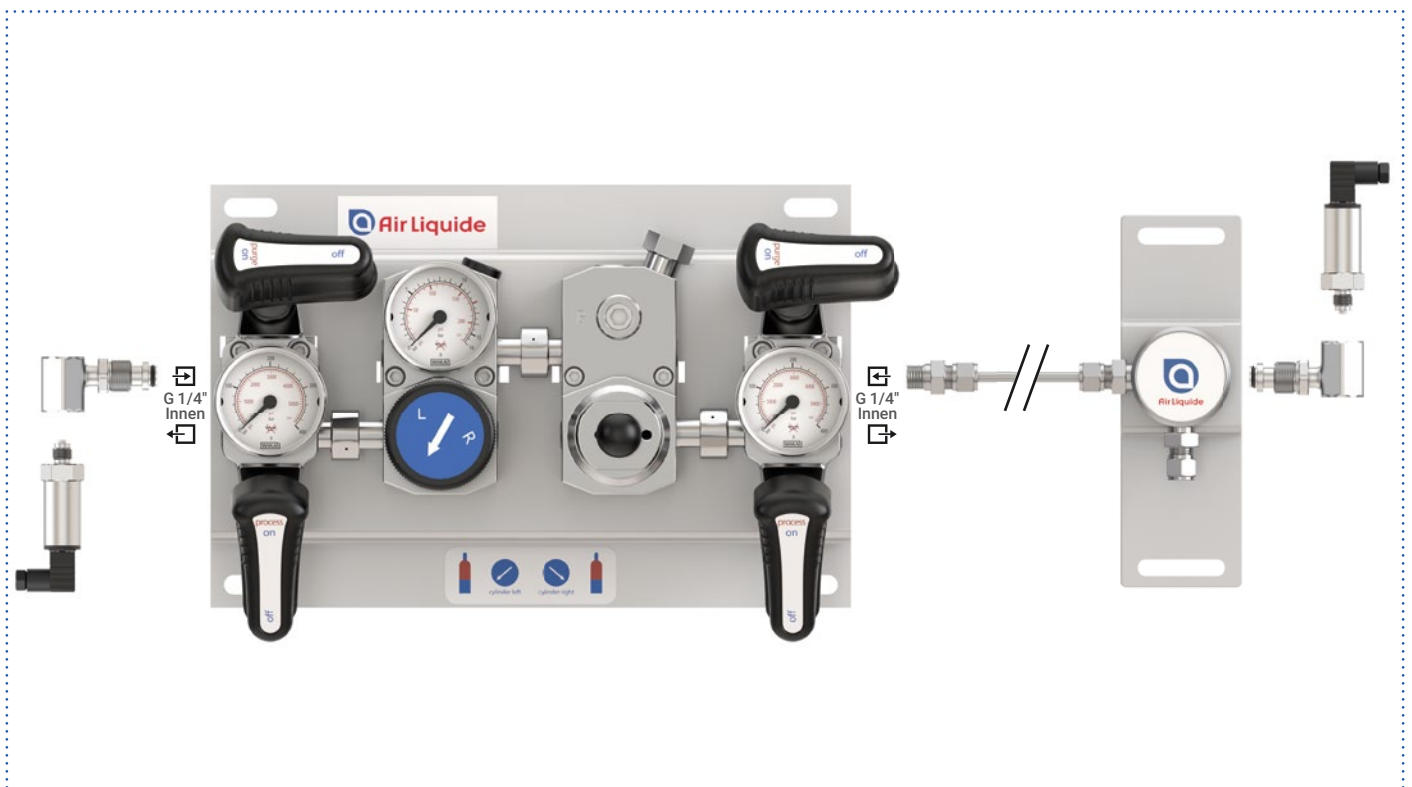

9 Instructions for operation and maintenance

9.1 Troubleshooting

Fault	Cause	Troubleshooting
Assembly not possible	Impossible assembly of the connections	Verify the compatibility with gases, inlet and outlet
	Damaged connection	Change the connection
Insufficient output of gas	Cross section passage limited by a valve.	Open the valve
	Insufficient filled or empty cylinder	Change the cylinder
	Not operating valve	Change the cylinder
	Under-dimensioned equipment	Contact AIR LIQUIDE
Equipment in output not operational	Equipment in output not operational	Change the equipment
The gas source in reserve drains without being used (Change over only)	Occasional over consumption	Replace by an equipment with a lower output
	Leakage	Check out the gas tightness
	Leakage at the main valve of the regulator	Replace the main valve or the regulator
At the same pressure and output entry, the outlet pressure is not the same which side you are using	Disturb regulators	Adjust the regulators
Gas comes out of the relief valve	Leakage at the flap of the regulator	Replace the regulator
	Defect relief valve	Replace the relief valve
Frosting	Too low working pressure	Close the cylinder valve. Increase the temperature of the equipment above 0 °C
	The used gas is argon (Ar), carbon dioxide (CO ₂) or nitrous oxide (N ₂ O)	Mount an heater at the inlet
The outlet pressure decreases	Output flow too high	Respect the regulator flow. Limit the flow by using a valve or a calibrated orifice.
Vibrations	Output flow too high	
	Presence of a valve with rapid opening on the outlet pipe.	Limit the flow by using a valve or a calibrated orifice.

In case of malfunctions such as:

- Increase in back pressure without removal,
- leakages of the manifold or the outlet valves,
- visible damage,
- response of the relief valve on the pressure regulator,
- response of a safety valve,

the system must be taken out of operation immediately in accordance with chapter 7.3 and a service technician must be informed.

9.2 Maintenance

Even though the equipment is reliable, it must be checked periodically.

Since this task requires some precautions, it must be done exclusively by a qualified technician.

The periodicity of this verification depends essentially on the usage of the equipment (intensive, moderate, occasional).

We suggest the use of the following table to ensure an optimum usage of your equipment:

V – to verify

C – to change

		Periodically										Annually		Every 5 years		
		Leakage	Operation	condition of threads	Sealing of closure	Fastening	Appearance	Setting	Safety	Cleanliness	Labelling	Seal	Setting	Filter	Electrical continuity	
Cylinder/Manifold connection	Flexible hoses /Pigtails	V		V		V	V			V	V	C			V	C
	Safety cable					V			V							C
	Racks					V	V									
	Chain					V	V									
	Fittings /Filters	V					V			V				V		C
Manifold	Support plate	V				V	V			V					V	
	HP Valves	V	V		V											
	Regulators	V	V		V		V	V					V			
	LP Valves	V	V		V											
	Relief valves	V			V											C
	Pressure Gauges	V	V				V									
	Filters															C
Others	2nd Stage reducer	V				V	V					C	V	C		
	Monitoring system	V	V							V						
	Pipe network	V		V	V	V				V	V			C	V	

The system should be checked by the manufacturer once a year for functional and operational safety. We recommend a maintenance contract – please do not hesitate to contact us.

The annual check of the flame back arrestors at downstream point of us is required by law. The proof of this must be provided by the operator.

Flexible hoses must be checked as required, at least at intervals within one year, in terms of their condition (integrity and tightness) by an expert or by the manufacturer.

9.3 Repairs

For safety reasons, repairs may only be carried out in authorized workshops or by the manufacturer.

Only original spare parts shall be used.

After each repair, the manifold must be checked for function and tightness. When putting the station back into operation the first thing to do is to purge the station with inert gas (e. g. nitrogen).

In the event of improper repairs by unauthorized workshops, modifications to the station or the use of non-original parts immediately voids all liability and warranty of the manufacturer.

For further information please contact our personal at your disposal.

9.4 Disposal and recycling

At the end of the equipment's useful life or when it is impossible to repair it, it is essential to respect the local regulations for recycling / disposal of our equipment. To prevent reuse, these products must be unsuitable for use.

In accordance with EU Directive 2018/851 on waste, the owner of the equipment ensures that when recovery is not carried out in accordance with article 10, the waste will be subjected to safe disposal operations that comply with the provisions of article 13 on the protection of human health and the environment.

The licensee must take steps to promote high quality recycling and, to this end, must establish separate waste collections when technically, environmentally and economically feasible and adequate to meet the quality standards required by the relevant recycling sectors.



10 Gas compatibility

Equipment	Parameters				Main gases														
	Item number	Adjustable Back pressures/ reserve (bar)	Nominal flow rate Nitrogen Nm³/h	Calibration of relief valve (bar)	Ammonia	Methane	Ethylene	Propylene	Propane	Acetylen	Hydrogen	Nitrous oxide	Oxygen	Synth. air	Breathable air	Carbon monoxide	Carbon dioxide	Argon-CO ₂ -mixture	Inert gases
SGA2-Stations brass chrome-plated																			
	200972	2 - 15	25	21	▲	▲	▲	▲	▲	▲	300	▲	▲	300	▲	▲	▲	▲	300
	154661	2 - 15	25	21	▲	●200	▲	▲	▲	▲	300	▲	●300	300	▲	▲	▲	▲	300
	154662	5 - 50	100	70	▲	▲	▲	▲	▲	▲	300	▲	●300	300	▲	▲	▲	300	300
	154663	2 - 15	25	21	▲	▲	▲	▲	▲	▲	300	44	●300	300	▲	▲	▲	300	300
	200973	2 - 15	25	21	▲	●200	▲	▲	▲	▲	300	▲	▲	300	▲	▲	▲	300	300
	173230	10,5 / 13,5	15	21	▲	▲	▲	▲	▲	▲	300	44	●300	300	▲	▲	▲	300	300
	173231	10,5 / 13,5	15	21	▲	●200	▲	▲	▲	▲	300	▲	▲	300	▲	▲	▲	300	300
	154656	41 / 50	100	70	▲	▲	▲	▲	▲	▲	300	▲	▲	300	▲	▲	▲	300	300
SGA2-Stations steel																			
	154660	0,5 - 3	5	4,2	▲	▲	▲	▲	▲	▲	▲	▲	▲	▲	▲	▲	▲	▲	▲
	154657	0,5 - 3	5	6	▲	●200	▲	▲	▲	▲	300	▲	▲	300	▲	▲	▲	300	300
	154658	2 - 15	25	21	▲	▲	▲	▲	▲	▲	300	▲	▲	300	▲	▲	▲	300	300
	154659	3 - 25	40	38	▲	▲	▲	▲	▲	▲	300	▲	▲	300	▲	▲	▲	300	300
	154652	9 / 12	15	17	▲	▲	▲	▲	▲	▲	300	▲	▲	300	▲	▲	▲	300	300
	154653	23 / 28	40	38	▲	●200	▲	▲	▲	▲	300	▲	▲	300	▲	▲	▲	300	300

Contact

Air Liquide Deutschland GmbH

Fütingsweg 34
47805 Krefeld
Tel: +49 (0) 2151 379 - 4555
equipment@airliquide.com
www.airliquide.de

Air Liquide Austria GmbH

Sendnergasse 30
2320 Schwechat
Tel: +43 810 242427
technik.at@airliquide.com
www.airliquide.at

Carbagas AG

Hofgut
3073 Gümligen
Tel: +41 31 95 05050
info@carbagas.ch
www.carbagas.ch

www.airliquide.de



A world leader in gases, technologies and services for Industry and Health, Air Liquide is present in 75 countries with approximately 66,400 employees and serves more than 3.8 million customers and patients.