

Dosing Valves

Operating manual



Dosing Valves

Content		Page
1	Preliminary notes	4
1.1	AIR LIQUIDE Commitments	4
1.2	Cleaning	4
1.3	Warranty	4
2	Field of usage	5
2.1	Functions	5
2.2	Intended use	5
3	Assembly / Activation	6
3.1	Safety	6
3.2	Precautions before assembly	6
3.3	Assembly	6
3.4	Activation	7
4	Maintenance	8
4.1	Maintenance	8
4.2	Disposal and recycling	8
5	Gas compatibility	9

RD60

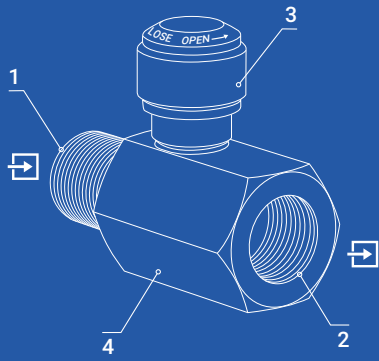

Millimite AN

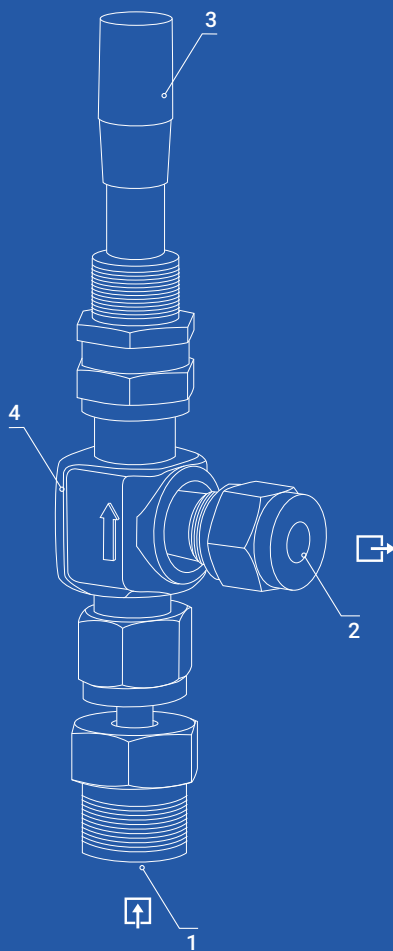

Millimite ST

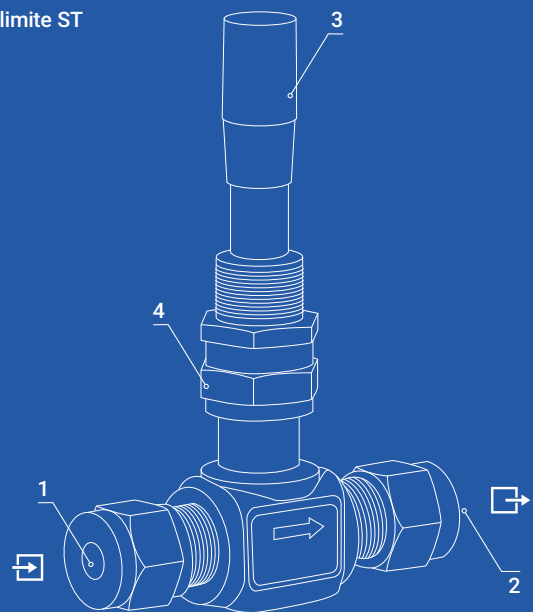

1. Inlet
2. Outlet
3. Handwheel for Dosing
4. Valve body

1 Preliminary notes

According to the legislator, the operator is responsible for the safety and health of his employees.

He must also provide employees with the necessary work equipment to prevent hazards from arising. In addition, must regularly monitor and document the safety-related systems document this.

This operating manual is intended to help that a small part of these requirements can be met.

Our equipment comply with the actual rules of regulation and are designed according to the state of the art.

1.1 AIR LIQUIDE Commitments

1.1.1 Conformity

AIR LIQUIDE certifies that the equipment is manufactured, tested and controlled, in accordance with state of the art and AIR LIQUIDE rules.

It is the responsibility of the end user to ensure that such equipment is installed and used in accordance with the current regulations

1.1.2 PED Directive 2014/68/EC: Pressurized equipment

Technical requirements of Article 4 § 3 indicates that pressure equipment and assemblies below or equal to the limits set out in points (a), (b) and (c) of paragraph 1 and in paragraph 2 respectively shall be designed and manufactured in accordance with the sound engineering practice of a Member State in order to ensure safe use.

Without prejudice to other applicable Union harmonisation legislation providing for its affixing, such equipment or assemblies shall not bear the CE marking referred to in Article 18.

By design, these equipment may integrate pressure relief valves or burst disks. In this case, those ones shall neither be CE marked according to paragraph 2 of annex II.

In all other cases, pressure relief valves and burst disks shall be CE marked.

1.1.3 ATEX Directive 2014/34/EC

The equipment is not in the scope defined in points a), b) and c) of the article of the ATEX Directive: consequently, they shall not wear the CE marking.

The equipment is not capable of causing an explosion through their own potential sources of ignition: then, they can be installed in ATEX zone 1 or 2, as far as respecting up to date regulations, rules, operating instructions, in accordance with the sound engineering practice are followed during installation and use.

Reminder: it belongs to the end user to define the ATEX zone.

1.1.4 REACH regulation (EC) n°1907/2006

The pressure reducers are made of brass parts, essentially the body, which is a copper alloy with a lead content between 1 % and 4 % w/w. As requested by art. 33 of REACH Regulation

(Registration, Evaluation and Authorisation of Chemicals) and with reference to current list of SVHC (substances of very high concern) available on ECHA website, we inform that lead may be present in a concentration above 0,1 % w/w in our products made of brass.

Lead inclusion in the SVHC list in June 2018 does not modify the use conditions described in operating instructions. Lead will not be released to the surrounding environment or the gas used during normal use.

After product end of life, the pressure reducers must be scrapped by an authorized metal recycler.

1.1.5 FOOD regulation (EC) n°1935/2004

The AL equipment enhancing the term "FOOD" in their designation are specifically designed for use with food gases used for food and beverage applications. They are compliant with Regulation EC 1935/2004 which requires that packaging and articles intended to be in contact with foodstuffs are to be manufactured in compliance with good manufacturing practices and standard operating procedures.

Thus under normal or foreseeable conditions of use, no transfer of contaminants, e.g. metal elements, to food in quantities that could endanger human health, modify food composition or deteriorate organoleptic characteristics is expected.

Nethertheless, the end-user must check the compliance with an eventual national regulation. Articles for food usage has a Food logo marking. For traceability purposes, the batch number is written on each article and AL can perform a batch recall, as requested by its Quality management system.

1.2 Cleaning

Each equipment is subject to a grease removal and a high quality cleaning to preserve the purity of gas in the equipment as well as for use with oxygen for compatible equipment.

A suitable packaging protects the equipment against exterior pollutants during storage and transport. Take care to avoid polluting the equipment during installation.

1.3 Warranty

Our "General Terms and Conditions of Sale and Terms of Delivery" apply. These are available to the operator at the latest upon conclusion of the contract. Warranty and liability claims for personal injury and property damage are excluded if they are attributable to one or more of the following causes:

- Improper use of the equipment.
- Improper installation, commissioning, operation and maintenance of the pressure and maintenance of the equipment.
- Operation of the pressure equipment with defective safety devices or improperly installed or or non-functioning safety and protective devices.
- Failure to observe the instructions in the operating manual regarding transport, storage, assembly, commissioning, operation, maintenance and set-up of the pressure equipment.
- Unauthorized structural modifications to the pressure equipment.

2 Field of usage

- Unauthorized alteration of the cylinder connections for the use of other types of gas, exceeding the permissible inlet pressure permissible inlet pressures, the use of foreign or non-original seals.
- Inadequate monitoring of equipment, screwed connections and sealing parts that are subject to wear.
- Improperly performed repairs.
- Exceeding or falling below the temperature range specified in the data sheet during operation or during storage.
- Catastrophic events due to the effects of foreign bodies and higher force majeure.

The warranty period of this equipment supplied by AIR LIQUIDE is one year, including spare parts and repair, excluding postage and packing costs. Excluded from the warranty are gaskets, these parts are subject to natural wear.

For further information please refer to the General Terms and Conditions of AIR LIQUIDE.

2.1 Functions

Air Liquide metering valves are designed primarily for use in connection with cylinder pressure regulators or point of use equipment. With these valves, the flow of the medium, with a certain pressure and accompanying flow rate, can be dosed.

Metering valves are usually not to be considered as shut-off valves.

2.2 Intended use

Metering valves are suitable for use with compressed and dissolved gases under pressure. The gas type and pressure range may vary depending on the type. These can be found in the gas compatibility table in Appendix 1 or in the current data sheet.

3 Assembly / Activation

3.1 Safety

Please read and observe the relevant safety instructions.
NEVER disassemble the valve while pressure is applied.

3.2 Precautions before assembly

After opening the packaging, check that the equipment is not damaged and that the contents correspond to the accompanying delivery notes.

- During assembly, it is important to take extreme care to ensure cleanliness and avoid contamination.
- To install the equipment, select a ventilated area, protected from the effects of bad weather.

3.3 Assembly

3.3.1 If necessary, remove already pre assembled outlet connections and seals (pos. 2).

3.3.2 Check the outlet of the equipment for cleanliness (pos. 2).

3.3.3 Insert the appropriate gasket (see data sheet).

3.3.4 Screw the dosing valve clockwise into the equipment, or fasten the dosing valve with a compression fitting in the pipeline.

3.3.5 If necessary, mount a suitable compression fitting/ hose nozzle on the outlet of the regulators and seal it using a suitable wrench.

3.3.6 Connect the hose nozzle to the outlet connection and to the consumer device. Link the hoses and hose connections (hose nozzles) according to the current standard. Secure hoses with suitable hose clamps.

3.3.7 The clamped metal tubes must always be softer than the material of the double ferrule fittings. For example, stainless steel tubes must never be used with brass tube fittings.

3.3.8 Support sleeves are always necessary for soft or flexible tubes. They give the hose the strength it needs for a leak-free seal.

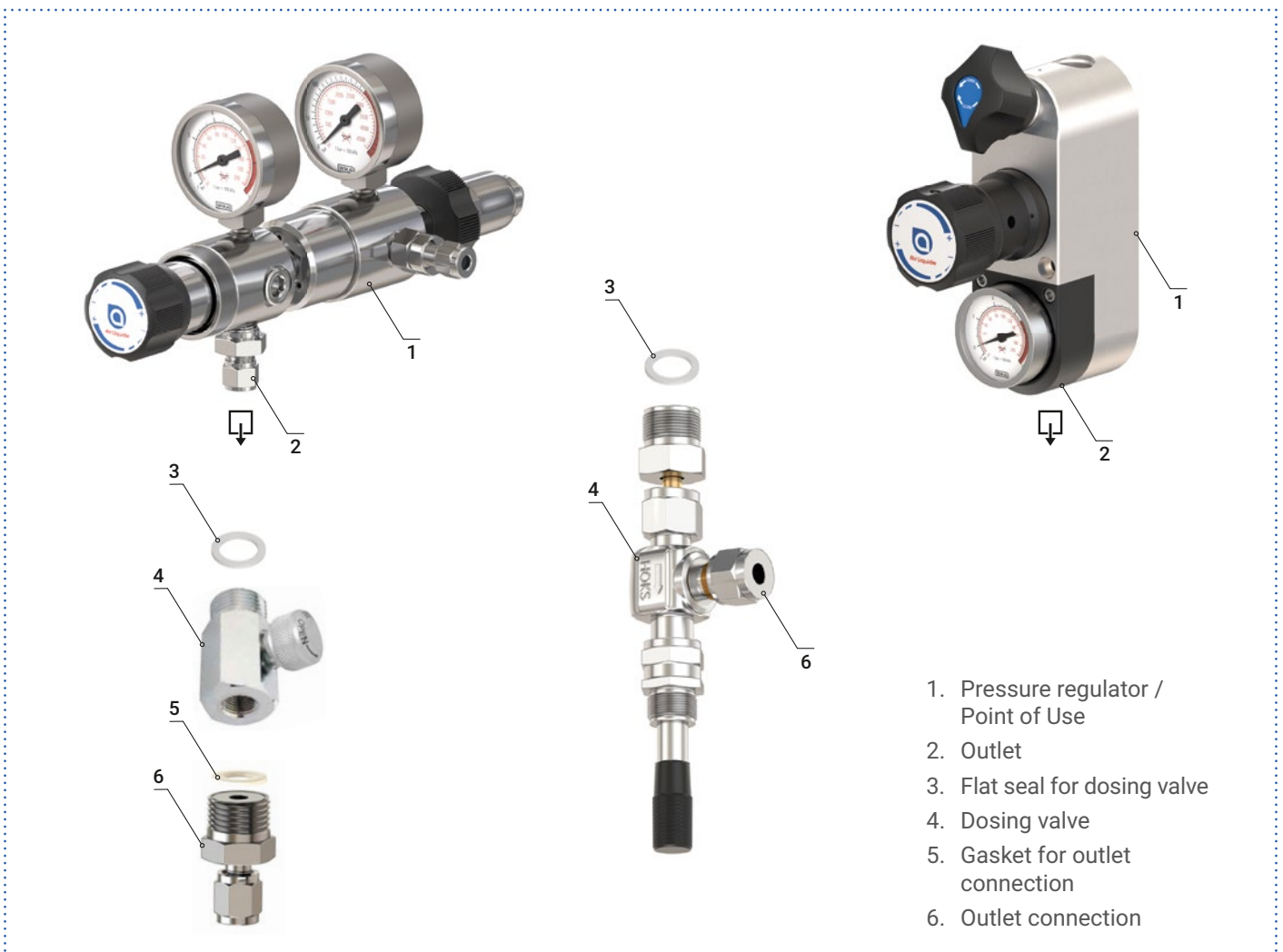

3.3.9 Make sure that the tube is cut perpendicular (a good quality tube cutter with a suitable cutting edge is recommended) and deburred. There must be no chamfer at the end of the pipe.

Insert the tube inside the connector up to the stop limit on the body. Clamp the nut completely by hand (Fig. 1).

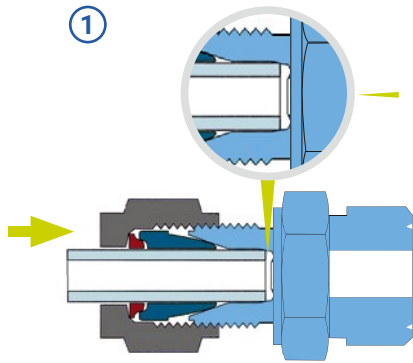

3.3.10 Hold the fitting body firmly and mark the position of the union nut. Complete the clamping using a wrench by turning the nut a 1 1/4 turn (Fig. 2). The connection is now correctly mounted.

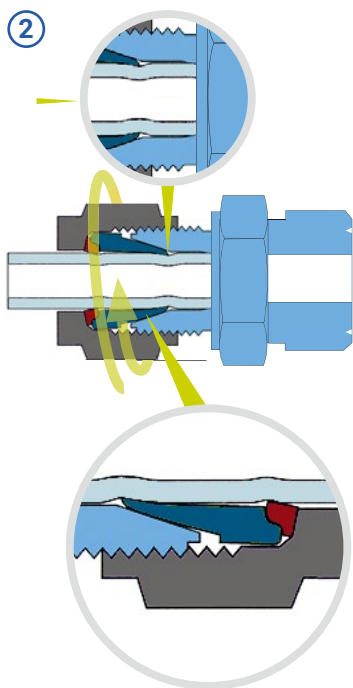

For screw connections up to 4 mm, only one 3/4 turn from the hand-tight position is permissible.

3.3.11 Instructions for reassembly

Connections can be loosened and retightened several times while maintaining a reliable, leak-free seal.

1. Before loosening the connection, mark the position of the mark the position of the nut in relation to the fitting body.
2. Push the pipe with pre-assembled clamping rings into the pipe until the pre clamping ring is firmly seated.
3. Tighten the union nut by hand. Then tighten the union with the spanner until you reach the old assembled state position. If you reach this position, you will notice an increased resistance when tightening. Then tighten the union nut lightly with the opened spanner. Smaller pipes require less tightening than large ones.

3.4 Activation

1. Slowly open the supply line.
2. Make sure the valve is correctly supplied.
3. Check for visible leaks on the system.
4. Gradually pressurize the downstream line.
5. Check the inlet and outlet fittings for leaks.
6. If necessary, turn off the supply, bleed the system and tighten the fittings which leak.



Never tighten a fitting while pressurized with gas.

7. Never use a tool to turn the handwheels. Always turn by hand.

4 Maintenance

4.1 Maintenance

AAir Liquide recommends annual periodic inspections of the pressure regulator by competent, authorized personnel. The frequency of this test depends mainly on the use of the device (intensive, moderate, occasional).

Faults that occur can have many causes. For your own safety, avoid tampering or making repairs on your own. In normal condition of use, discarding after 10 years in working.

4.2 Disposal and recycling

At the end of the equipment's useful life or when it is impossible to repair it, it is essential to respect the local regulations for recycling / disposal of our equipment.

To prevent reuse, these products must be unsuitable for use. In accordance with EU Directive 2018/851 on waste, the owner of the equipment ensures that when recovery is not carried out in accordance with article 10, the waste will be subjected to safe disposal operations that comply with the provisions of article 13 on the protection of human health and the environment.

The licensee must take steps to promote high quality recycling and, to this end, must establish separate waste collections when technically, environmentally and economically feasible and adequate to meet the quality standards required by the relevant recycling sectors.



5 Gas compatibility

Main gases	Ammonia	▲	▲	▲
	Methane	▲	● 200	● 200
	Ethylene	▲	● 70	● 70
	Propylene	▲	● 10	● 10
	Propane	▲	● 10	● 10
	Acetylen	● 1,5	● 1,5	● 1,5
	Hydrogen	● 60	● 200	● 200
	Nitrogen monoxide	● 25	● 200	● 200
	Oxygen	● 25	● 200	● 200
	Compressed air (non breathable)	● 60	● 200	● 200
	Compressed air (breathable)	▲	▲	▲
	Carbon monoxide	▲	● 200	● 200
	Carbon dioxide	● 60	● 200	● 200
	Argon, Argon/CO ₂	● 60	● 200	● 200
	Inert Gases*, Nitrogen	● 60	● 200	● 200
Parameters	Flow coefficient KV	0,10	0,02	0,02
	Seat diameter	2,5	1,2	1,2
	Max. Operating pressure	60	200	200
	Item number	212343	16129	16127
Catalogue page	109	116		
Designation		RD60 60-0,10	Millimite 200-0,02..AN	Millimite 200-0,02..ST

● 50 Suitable up to an operating pressure of ...

▲ Not suitable

* Inerte gases = Nitrogen, Argon, Helium

Contact

Air Liquide Deutschland GmbH

Fütingsweg 34
47805 Krefeld
Tel: +49 (0) 2151 379 - 9444
equipment@airliquide.com
www.airliquide.de

Air Liquide Austria GmbH

Sendnergasse 30
2320 Schwechat
Tel: +43 810 242427
technik.at@airliquide.com
www.airliquide.at

Carbagas AG

Hofgut
3073 Gümligen
Tel: +41 31 95 05050
info@carbagas.ch
www.carbagas.ch

www.airliquide.de



A world leader in gases, technologies and services for Industry and Health, Air Liquide is present in 73 countries with approximately 67,100 employees and serves more than 3.9 million customers and patients.