



Operating Instructions for
Point of Use for pure gas

OP 450
Version: 1
Date : 07-2023
Owner : SWE
Language: EN

**Operating Instructions
for
Point of Use for pure gas**

OP	Models
OP451	PDG-D 50-10-10
OP452	PDG-A ; PDG-B; PDG-B.S; PDG-PHARMA

	Operating Instructions Point of Use PDG-D 50-10-10	OP 451 Version: 1 Date : 04-2023 Owner : SWE Language: EN
---	---	--

Operating Instructions

PDG-D **50-10-10**

Warning

To preserve the quality of our product throughout its usage in the best safety conditions, please read this manual carefully and strictly follow the instructions that it contains. Non-compliance with these instructions or modification of the product may result in serious accidents or bodily injuries. Air Liquide shall not be held responsible in case of non-approved usage of the product.

Air Liquide reserves the right to make all necessary modifications to the specifications described hereafter without notice.

CONTENTS

1.FIELD OF USAGE AND CHARACTERISTICS	3
1.1 Functions	3
1.2 Technical characteristics	3
1.3 Gas compatibility table	3
2.AIR LIQUIDE COMMITMENTS	4
2.1 Conformity	4
2.2 Cleaning	5
2.3 Inspections	5
2.4 Warranty	5
3.ASSEMBLY-ACTIVATION	5
3.1 Safety	5
3.2 Precautions before assembly	5
3.3 Assembly	6
3.3.1 Pipe network set up	6
3.4 Assembly of a compression fitting	6
3.5 Activation	6
3.5.1 Checking of leakage on the upstream circuit	6
3.5.2 Checking of leakage on the downstream circuit	7
4.USAGE	8
4.1 Use	8
4.2 After use	8
5.MAINTENANCE	9
5.1 Troubleshooting	9
5.2 Maintenance	9
6.APPENDIX	10
6.1 Gas compatibility tables	10
6.2 Drawings	10
6.3 Wall support	11
6.3 Flow curve	12

1.FIELD OF USAGE AND CHARACTERISTICS

1.1 Functions

Low pressure point of use regulator suitable for high purity gases in laboratory applications. The point of use block made from aluminium contains a diaphragm shut off valve, an adjustable diaphragm regulator and an indicating pressure gauge. To be mounted individually or with adjacent on wall plates.

The PDG-D-50-10-10 functions are :

- reducing a pressure gas downstream from a gas source (from 1.5 bar to 50 bar, depending on the model and gases).
- regulate and maintain stability of the outlet pressure.
- preserve the gas purity.
- allow or stop the gas flow.

The PDG-D Points of Use are designed for implementation of pure gases and mixtures with purity until 6.0, i.e. N60 thus ALPHAGAZ 1 and 2.

1.2 Technical characteristics

Maximum inlet pressure: 50 bar

Operating temperature : - 25°C to + 70°C

Leakage rate:

- internal: $\leq 1 \times 10^{-6}$ mbar.l/s helium.
- external: $\leq 3 \times 10^{-9}$ mbar.l/s helium.

1.3 Gas compatibility table

IMPERATIVE: check the gases compatibility of this equipment by referring to the "Gas Compatibility Table.

See in "APPENDIX".

2.AIR LIQUIDE COMMITMENTS

2.1 Conformity

AIR LIQUIDE certifies that this equipment is manufactured, tested and controlled, in accordance with state of the art and AIR LIQUIDE rules.

In addition to technical specifications, a degreasing process consistent with oxygen service is applied.

It is the responsibility of the end user to ensure that such equipment is installed and used in accordance with the regulations.

Directive 2014/68/EC: Pressurized equipment (PED)

Technical requirements of Article 4§3 indicate that Pressure equipment and assemblies below or equal to the limits set out in points (a), (b) and (c) of paragraph 1 and in paragraph 2 respectively shall be designed and manufactured in accordance with the sound engineering practice of a Member State in order to ensure safe use.

Without prejudice to other applicable Union harmonisation legislation providing for its affixing, such equipment or assemblies shall not bear the CE marking referred to in Article 18. By design, this equipment may integrate pressure relief valves or burst disks. In this case, those ones shall not be CE marked according to paragraph 2 of annex II.

In all other cases, pressure relief valves and burst disks shall be CE marked.

Directive 2014/34/UE ATEX :

The equipment is not in the scope defined in points a), b) et c) of the article of the ATEX Directive: consequently, they shall not bear the CE marking.

The equipment is not capable of causing an explosion through their own potential sources of ignition: then, they can be installed in ATEX zone 1 or 2, as far as respecting up to date regulations, rules, operating instructions, in accordance with the sound engineering practices that are followed during installation and use.

Reminder: it belongs to the end user to define the ATEX zone.

REACH regulation (EC) n°1907/2006 :

The PDG-D is made of aluminium.

As stated in art.33 of REACH Regulation (Registration, Evaluation and Authorisation of Chemicals), the equipment does not contain any list of SVHC (substances of very high concern), with reference to the current list available on the ECHA website.

After product end of life, the pressure reducers must be scrapped by an authorized metal recycler.

2.2 Cleaning

Each piece of equipment is subject to a grease removal and a high quality cleaning to preserve the purity of gas in the equipment as well as for use with oxygen for compatible equipment.

A suitable packaging protects the equipment against exterior pollution during storage and transport.

Take care to avoid polluting the equipment during installation.

2.3 Inspections

All equipment is inspected and undergoes a certified helium leak test prior to packing and dispatch.

2.4 Warranty

The warranty period for equipment supplied by AIR LIQUIDE is one year, covering faulty material or faulty workmanship during manufacturing. The warranty however does not cover packing or return transport costs.

Excluded from warranty: seals and relief valves. These components are subject to natural wear and tear.

Warranty is not valid for deterioration resulting from incorrect or improper use, use of spare parts which are not recommended by AIR LIQUIDE or for not following these operating instructions.

For more information, refer to the general sales conditions of AIR LIQUIDE.

3.ASSEMBLY-ACTIVATION

3.1 Safety

First of all, it is ESSENTIAL to read and follow the safety instructions described in the document "General Safety Instructions" delivered with the product.

3.2 Precautions before assembly

After opening the package, check that the equipment is not damaged and that the contents correspond to the delivery notes accompanying the equipment.

- During assembly, it is important to take extreme care to ensure cleanliness and avoid contamination.
- The Points of Use are designed to be directly mounted on a pipe network panel or at the end of the pipeline.
- Make sure that the pipes are clearly identified for the gas used with a marking on the tubes following local regulation.

3.3 Assembly

3.3.1 Pipe network set up

The PDG-D Points of Use shall be connected at the top* (visible piping).

For this, they have:

- 1 inlet port G3/8 BSPP Female, side "Shut-off valve"
 - 1 outlet port G3/8 BSPP Female, side "Pressure gauge"
-
- Make sure that the supplied outlet fittings match the application
 - Position the seals
 - Screw the fitting on the regulator outlet port (tighten to **35 Nm** with a wrench)
 - Make sure that the caps unused ports are positioned correctly
 - Connect the pipe network and firmly attach to the wall in order to avoid the risk of flapping
 - Install a pressure safety valve on the pipe if requested by risk analysis
 - Identify the gas used on the inlet piping following standards

3.3.2 Panel set up

Attach the PDG-D vertically on the wall or on the support plate with 4 screws Ø 5mm.

3.4 Assembly of a compression fitting

Check dimensions and respect material compatibility between connection and pipe: Connection and pipe must always be made from the same material, for example: Stainless steel connection for stainless steel pipe <Rockwell hardness B90 (exception : brass connection with copper pipe).

- Connector pre-assembled by hand
- After cutting (preferably with a tube cutter), deburring and blowing gas through the tube , pre-assemble the nut and the ferrules, following the steps in order and the positions indicated in the illustration.
- Introduce the tube inside the connector up to the stop limit on the body
- Clamp the nut completely by hand
- Complete the clamping using a wrench by turning the nut a 1 and 1/4 turn.

3.5 Activation

Even if the tightness of each regulator is tested in a factory, it is necessary to ensure there is no leakage on the connections made during the assembly.

Before carrying out this check, make sure that the downstream circuit is closed (towards the application).

3.5.1 Checking of leakage on the upstream circuit

- Close the Point of Use shut-off valve ,
- Open the gas supply of the network,
- Check the leakage on the inlet fitting by using a leak detector.

In the event of leakage:

- Stop the gas flow
- Purge the Point of Use
- Check the seals and, if necessary, change them
- Make sure that the tubes are fully inserted in the compression fittings
- Check the ferrules, and, if necessary, change them
- Retighten the compression fitting nut

3.5.2 Checking of leakage on the downstream circuit

- Make sure that the valve on the outlet circuit is closed.
- Open the shut-off valve of the Point of Use.
- Turn the regulator's handwheel , 2 turns counterclockwise.
- Check the leakage on the outlet fitting by using a leak detector.

In the event of leakage:

- Turn the regulator's handwheel counterclockwise and close the shut-off valve of the Point of Use.
- Purge the Point of Use.
- Check the seals and, if necessary, change them.
- Make sure that the tubes are fully inserted in the compression fittings.
- Check the ferrules, if necessary, change them.
- Retighten the compression fitting nut.

→ **WARNING** : Always turn valves GRADUALLY.

→ **NOTA BENE**: NEVER retighten a fitting under gas pressure.

4.USAGE

4.1 Use

- Verify that the regulator handwheel is slacked off (counterclockwise) and the upstream circuit valve is closed
- Slowly open the Point of Use shut-off valve of
- Turn the handwheel clockwise until you start feeling resistance. Then continue until you reach the required working pressure
- Now the Point of Use is ready to supply the working pressure.
- Open the outlet valve
- If necessary, adjust the outlet pressure

To stop the gas flow, close the valve upstream of the regulator.

4.2 After use

When the Point of use is no longer used:

- Close the shut-off valve.
- Lower the pressure by the outlet .
- Loose the handwheel of the regulator.

5.MAINTENANCE

5.1 Troubleshooting

Default	Cause	Remedy
Mounting impossible	Connections cannot be mounted	Verify the thread, inlet and outlet
	Damaged connections	Replace the PDG-D
Insufficient flow rate	Cross section of passage limited by a valve	Open the valve
	Under-dimensional equipment	Check the PDG-D flow curve
	Downstream device not operational	Change the device
Gas leak	Tightness default	Close the cylinder valve and replace the regulator
Rise of the outlet pressure	Leakage at the poppet	
Unstable outlet pressure	Flow rate too high	Respect the max. flow rate of the regulator. Limit the flow by a valve or a calibrated orifice
Vibrations	Presence of valve with quick opening on the downstream pipe	Limit the flow by a valve or a calibrated orifice

5.2 Maintenance

Even though the equipment is reliable, it must be checked periodically. Since this task requires some precautions, it must be done exclusively by a qualified technician.

The periodicity of this verification depends essentially on the usage of the equipment (intensive, moderate, occasional).

In case of an operating accident (insufficient output, leakage, opening of the relief valve or accidental damage) : replace the equipment.

- Do not modify the equipment,
- Never dismantle any of the equipment's components.

Defective reassembly may cause bursting, malfunctioning and/or an increasing output pressure, which is dangerous for your safety.

6.APPENDIX

6.1 Gas compatibility tables

Model	Inerts (N ₂ ,Ar, He)	CO ₂	CO	Air*	O ₂	N ₂ O	H ₂	C ₂ H ₂	C ₃ H ₈	C ₃ H ₆	C ₂ H ₄	CH ₄
PDG-D 50-10-10	Y	Y	Y	Y	N	N	Y	N	N	N	N	N

* Air: compressed air not breathable

In case of use with mixed gas with corrosive species, check the compatibility between the equipment components, especially seals in EPDM, PVDF and PTFCE, and the gas used.

It may be suitable for short term use under ambient conditions and in diluted form.

6.2 Drawings

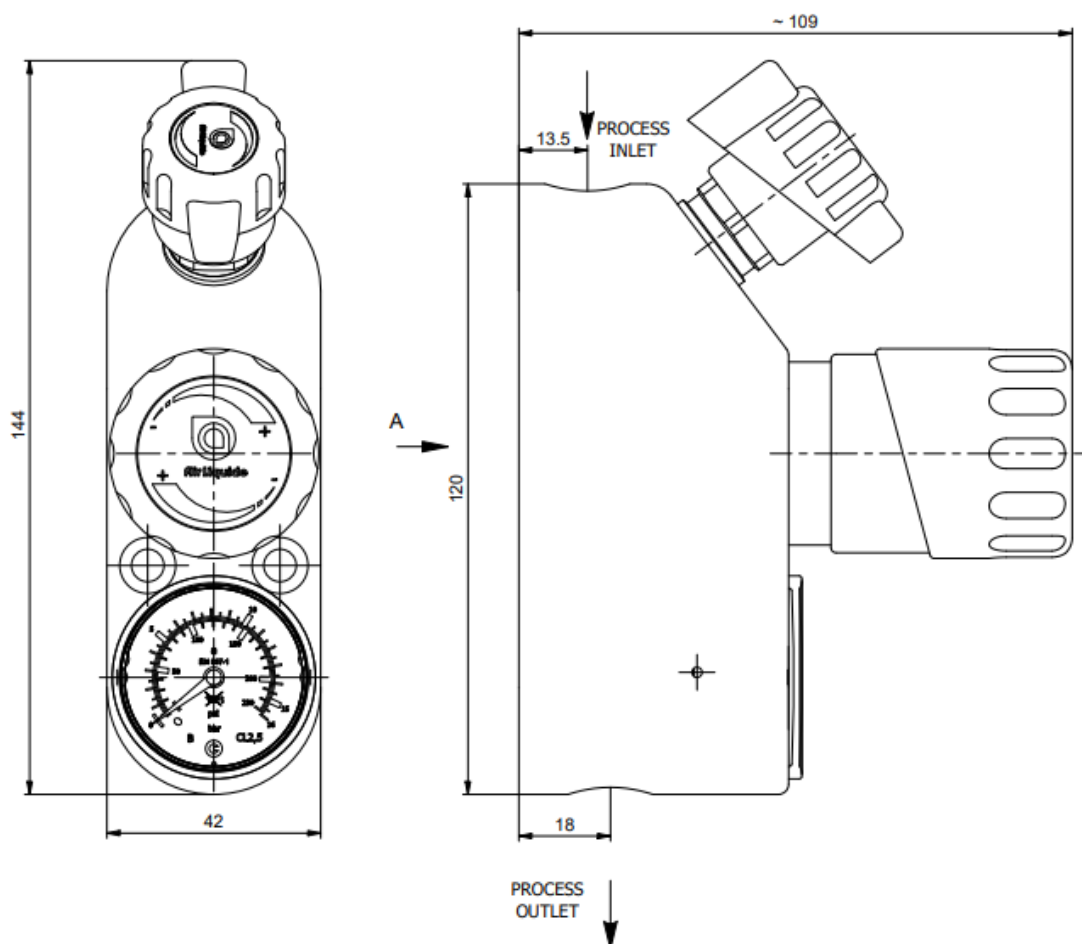

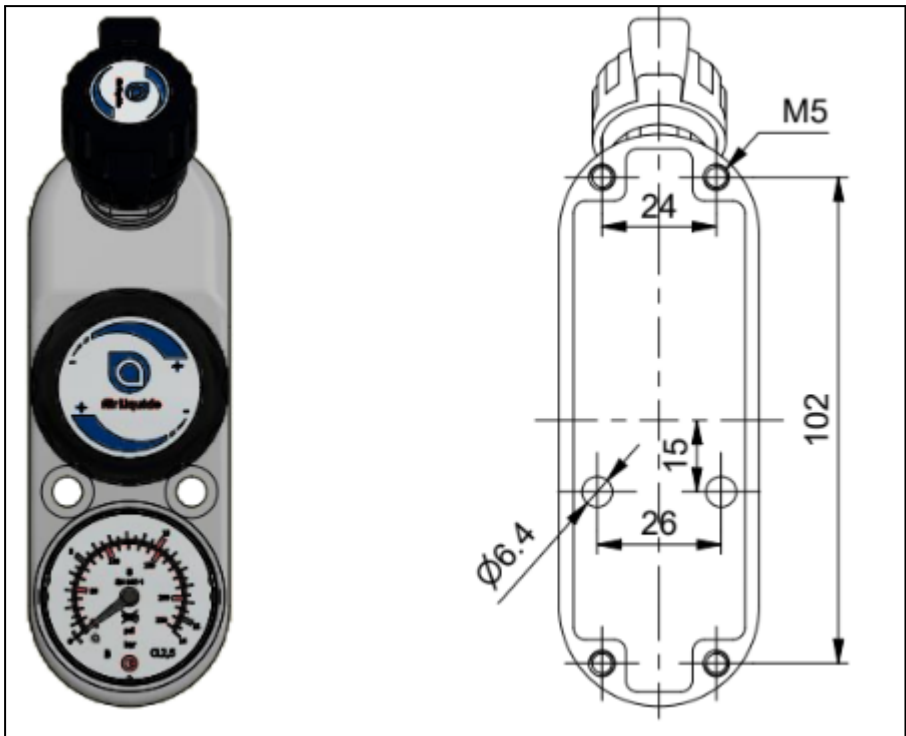

6.3 Wall support

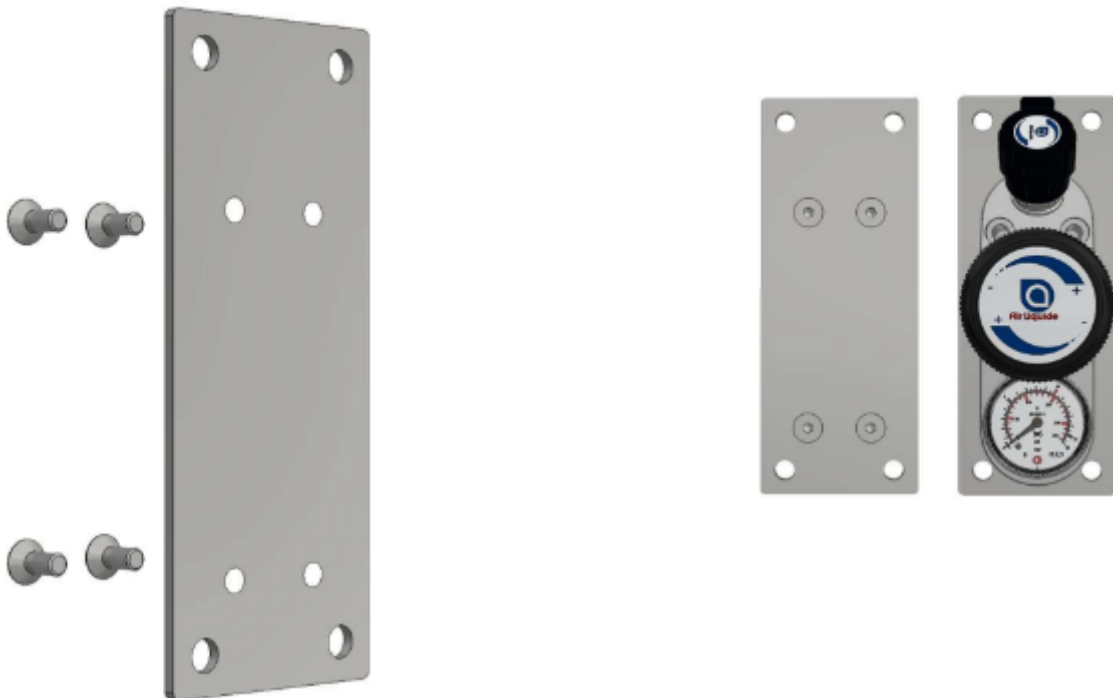

6.4 Flow curve

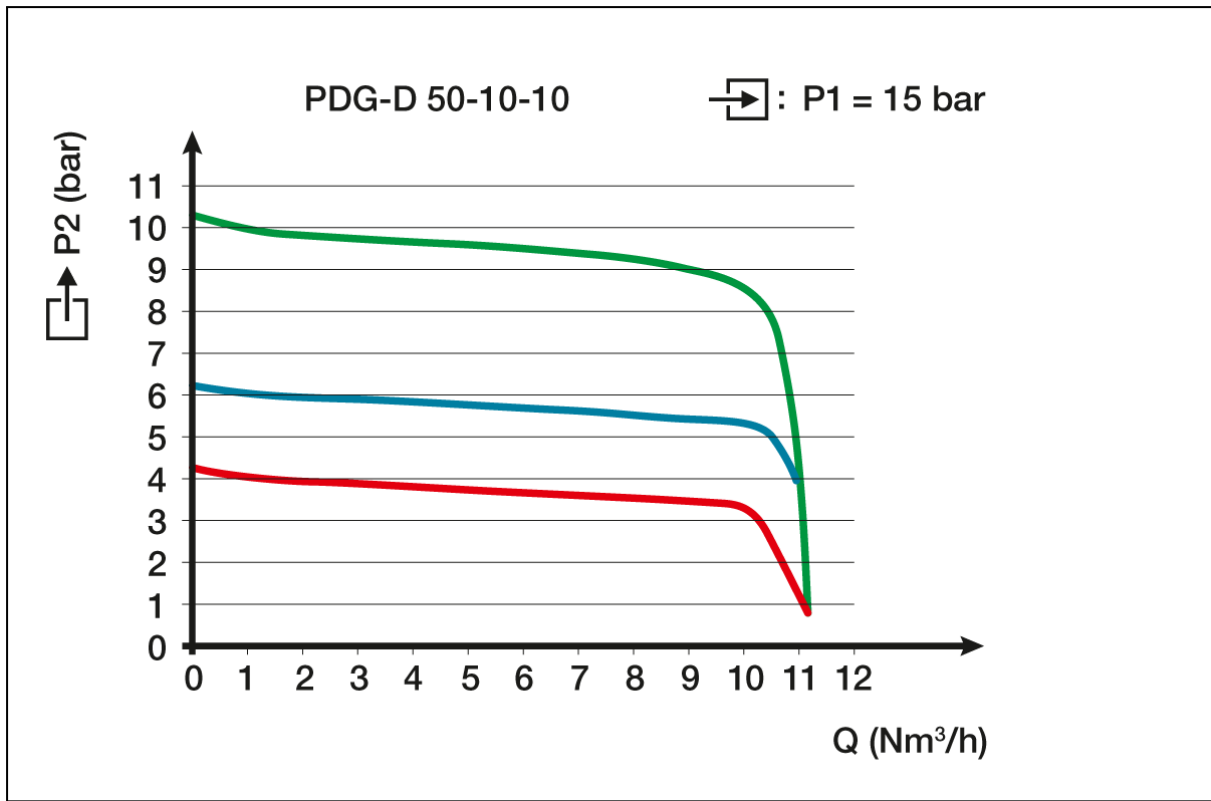

To contact us :

Air Liquide France Industrie

Service Client - Tél. +33(0)9 70 25 00 00

email: **contact.alfi@airliquide.com**

Customer service : **mygas.airliquide.fr**

www.airliquide.fr



Air Liquide France Industrie - Société Anonyme au capital de 72.267.600 Euros - Siège social : 6 rue Cognacq-Jay, 75007 Paris - RCS Paris 314 119 504.

	Operating Instructions Point of Use for Pure Gases	OP 452 Version: 1 Date : 07-2023 Owner : SWE Language: EN
---	---	--

Operating Instructions

PDG

Brass or aluminium body	Stainless steel body
PDG-B	PDG-B.S
PDG-D	PDG-D.S Pharma
PDG-A	

Warning

To preserve the quality of our product throughout its usage in the best safety conditions, please read this manual carefully and strictly follow the instructions that it contains. Non-compliance with these instructions or modification of the product may result in serious accidents or bodily injuries. Air Liquide shall not be held responsible in case of non-approved usage of the product.

Air Liquide reserves the right to make all necessary modifications to the specifications described hereafter without notice.

CONTENTS

1. FIELD OF USAGE AND CHARACTERISTICS	2
1.1 Functions	2
1.2 Technical characteristics	2
1.3 Gas compatibility table	2
2. AIR LIQUIDE COMMITMENTS	3
2.1 Conformity	3
2.2 Cleaning	4
2.3 Inspections	4
2.4 Warranty	4
3. ASSEMBLY-ACTIVATION	4
3.1 Safety	4
3.2 Precautions before assembly	4
3.3 Assembly	5
3.3.1 Pipe network set up	5
3.3.2 Panel set up	5
3.4 Assembly of a compression fitting	5
3.5 Activation	5
3.5.1 Checking of leakage on the upstream circuit	6
3.5.2 Checking of leakage on the downstream circuit	6
4. USAGE	6
4.1 Use	6
4.2 After use	6
5. MAINTENANCE	7
5.1 Troubleshooting	7
5.2 Maintenance	8
6. APPENDIX: Gas compatibility tables	8
6.1 PDG Points of Use	8
6.2 PDG.S Points of Use	9
6.3 PDG.A Points of Use	9
7. DIMENSIONS	9
7.1 Points of use	9
7.2 Plates	9

1. FIELD OF USAGE AND CHARACTERISTICS

1.1 Functions

The ALPHAGAZ PDG, PDG.S, PDG.S Pharma, PDG-B, PDG-D, PDG-B.S, PDG-D.S, PDG-D.S Pharma and PDG-A Points of Use are used for :

- reduce a pressure gas downstream from a gas source (from 1.5 bar to 50 bar, depending on the model and gases).
- regulate and maintain stability of the outlet pressure.
- preserve the gas purity.
- allow or stop the gas flow.

The ALPHAGAZ PDG and PDG.S Points of Use are designed for implementation of pure gases and mixtures with purity < N60 thus ALPHAGAZ 1 and 2. The ALPHAGAZ PDG-A Points of Use are especially designed for implementation of pure acetylene.

1.2 Technical characteristics

Operating temperature : - 30°C to + 50°C

Leakage rate (Int/Ext.) : $\leq 3 \times 10^{-7}$ mbar.l/s helium.

1.3 Gas compatibility table

IMPERATIVE: check the gases compatibility of this equipment by referring to the "Gas Compatibility Table.

See in "APPENDIX".

2. AIR LIQUIDE COMMITMENTS

2.1 Conformity

AIR LIQUIDE certifies that this equipment is manufactured, tested and controlled, in accordance with state of the art and AIR LIQUIDE rules.

In addition to technical specifications, a degreasing process consistent with oxygen service is applied. It is the responsibility of the end user to ensure that such equipment is installed and used in accordance with the regulations.

Directive 2014/68/EC: Pressurized equipment (PED)

Technical requirements of Article 4§3 indicates that Pressure equipment and assemblies below or equal to the limits set out in points (a), (b) and (c) of paragraph 1 and in paragraph 2 respectively shall be designed and manufactured in accordance with the sound engineering practice of a Member State

in order to ensure safe use.

Without prejudice to other applicable Union harmonisation legislation providing for its affixing, such equipment or assemblies shall not bear the CE marking referred to in Article 18.

By design, these equipment may integrate pressure relief valves or burst disks. In this case, those ones shall neither be CE marked according to paragraph 2 of annex II.

In all other cases, pressure relief valves and burst disks shall be CE marked.

Directive 2014/34/UE ATEX :

The equipment is not in the scope defined in points a), b) et c) of the article of the ATEX Directive: consequently, they shall not bear the CE marking.

The equipment are not capable of causing an explosion through their own potential sources of ignition: then, they can be installed in ATEX zone 1 or 2, as far as respecting up to date regulations, rules, operating instructions, in accordance with the sound engineering practice are followed during installation and use.

Reminder: it belongs to the end user to define the ATEX zone.

REACH regulation (EC) n°1907/2006 :

The PDG-D are made of brass parts, essentially the body, which is a copper alloy with a lead content between 1% and 4% w/w.

As requested by art.33 of REACH Regulation (Registration, Evaluation and Authorisation of Chemicals) and with reference to current list of SVHC (substances of very high concern) available on ECHA website, we inform that lead may be present in a concentration above 0,1% w/w in our products made of brass.

Lead inclusion in the SVHC list in June 2018 does not modify the use conditions described in operating instructions.

Lead will not be released to the surrounding environment or the gas used during normal use.

After product end of life, the pressure reducers must be scrapped by an authorized metal recycler.

2.2 Cleaning

Each equipment is subject to a grease removal and a high quality cleaning to preserve the purity of gas in the equipment as well as for use with oxygen for compatible equipment.

A suitable packaging protects the equipment against exterior pollution during storage and transport.

Take care to avoid polluting the equipment during installation.

2.3 Inspections

Equipment is inspected and has undergone a certified helium leak test prior to packing and dispatch.

2.4 Warranty

The warranty period for equipment supplied by AIR LIQUIDE is one year, covering faulty material or workmanship during manufacture. The warranty does not cover packing and return transport costs.

Excluded from warranty: seals and relief valves. These components are submitted to a natural wear. Warranty is not valid on deterioration resulting from incorrect or improper use, use of spare parts which are not recommended by AIR LIQUIDE or from the none respect of this operating instruction.

For more information, refer to the general sales conditions of AIR LIQUIDE.

3. ASSEMBLY-ACTIVATION

3.1 Safety

First of all, it is ESSENTIAL to read and respect the safety instructions described in the document "General Safety Instructions" delivered with the product.

3.2 Precautions before assembly

After opening the packaging, check that the equipment is not damaged and that the contents correspond to the delivery notes accompanying the equipment.

- During assembly, it is important to take extreme care to ensure cleanliness and avoid contamination.
- The Points of Use are designed to be directly mounted on a pipe network panel or at the end of the pipeline.
- To install the equipment, select a ventilated area, protected from the effects of bad weather.

3.3 Assembly

3.3.1 Pipe network set up

The PDG, PDG.S PDG.S Pharma, PDG-B, PDG-D, PDG-B.S, PDG-D.S, PDG-D.S Pharma and PDG-A Points of Use can be connected at the rear (hidden piping) or at the top* (visible piping). For this, they have:

- 2 inlet ports G3/8 BSPP Female, side "Shut-off valve",
- 2 outlet ports G3/8 BSPP Female, side "Pressure gauge".

* By rotating the Point of Use, the input can be at the bottom (in the correct direction with the manometer gauge joints of different thicknesses).

- Make sure that the supplied outlet fittings match the application.
- Put in place the seals.
- Screw the fitting on the regulator outlet port (tighten to 35 mN with a wrench).
- Check the presence of the caps on unused ports.
- Connect the pipe network and strongly fix it to avoid risks of flapping.
- Install a relief valve suited to the application on the pipe.

3.3.2 Panel set up

- Fix the equipment to the wall or on the plate with 2 screws Ø 5mm.

3.4 Assembly of a compression fitting

Check dimensions and respect material compatibility between connection and pipe: Connection and pipe must always be made from the same material, example: Stainless steel connection for stainless steel pipe <Rockwell hardness B90 (exception : brass connection with copper pipe).

Connector pre-assembled by hand

- After cutting, deburring and blowing on the tube (use preferably a tube cutter), pre-assemble the nut and the ferrules, following the order and the direction indicated in the figure.
- Introduce the tube inside the connector up to the stop limit on the body.
- Clamp the nut completely by hand
- Complete the clamping using a wrench by turning the nut a 1-1/4 turn.

3.5 Activation

Even if the tightness of each regulator is tested in a factory, it is necessary to ensure there is no leakage on the connections made during the assembly. Before carrying out this check, make sure that the downstream circuit is closed (towards the application).

Never stand directly in front of the cylinder valve outlet while opening it.

3.5.1 Checking of leakage on the upstream circuit

- Close the shut-off valve of the Point of Use,
- Open the gas supply of the network,
- Check the leakage on the inlet fitting by using a leak detector.

In case of Leakage:

- Stop the gas flow.
- Purge the Point of Use.
- Check the seals and, if necessary, change them.
- Make sure that the tubes are fully inserted in the compression fittings.
- Check the ferrules, if necessary, change them.
- Retighten the compression fitting nut.

3.5.2 Checking of leakage on the downstream circuit

- Make sure that the valve on the outlet circuit is closed.
- Open the shut-off valve of the Point of Use.
- Turn the regulator's handwheel , 2 turns counterclockwise.
- Check the leakage on the outlet fitting by using a leak detector.

In case of Leakage:

- Turn the regulator's handwheel counterclockwise and close the shut-off valve of the Point of Use.
- Purge the Point of Use.

- Check the seals and, if necessary, change them.
- Make sure that the tubes are fully inserted in the compression fittings.
- Check the ferrules, if necessary, change them.
- Retighten the compression fitting nut.

Always turn valves GRADUALLY. NEVER retighten a fitting under gas pressure.

4. USAGE

4.1 Use

Verify that the regulator handwheel is unscrewed counterclockwise and the upstream circuit valve is closed.

Slowly open the shut-off valve of the Point of Use.

Turn the handwheel clockwise until you start feeling resistance . Then continue until you reach the required working pressure.

Now the Point of Use is ready to supply the working pressure.

Open the outlet valve.

If necessary, adjust the outlet pressure. To stop the gas flow, close the valve upstream of the regulator.

4.2 After use

When the Point of use is no longer used:

- Close the shut-off valve
- release the pressure through the outlet
- Loose the handwheel of the regulator

5. MAINTENANCE

5.1 Troubleshooting

Default/issues	Cause	Remedy
Mounting impossible	Connections can not be mounted	Verify the compatibility of gases with the material of, inlet and outlet
	Damaged connections	Replace the regulator
Insufficient flow rate	Cross section of passage limited by a valve	Open the valve
	Undersized equipment	Contact Air Liquide
	Downstream device not operational	Change the device
Gas leak	Insufficient Tightness	Close the cylinder valve and replace the regulator
Rise of the outlet pressure	Leakage at the poppet	
Unstable outlet pressure or frosting	Flow rate too high	Respect the max. flow rate of the regulator. Limit the flow with a valve or a calibrated orifice
Vibrations	Presence of a quick-opening valve on the downstream pipe	Screw the valve to limit the flow or a calibrated orifice

5.2 Maintenance

Even though the equipment is reliable, it must be checked periodically. Since this task requires some precautions, it must be done exclusively by a qualified technician.

The frequency of this verification depends essentially on the usage of the equipment (intensive, moderate, occasional). We recommend replacing it every 5 years.

In the event of an operating accident (insufficient output, leakage, opening of the relief valve or accidental damage), replace the equipment.

- Use only original parts and do not modify the equipment.
- Never dismantle any of the equipment's components.

Defective reassembly may cause bursting, malfunctioning and/or increasing output pressure, which is dangerous for your safety.

6.APPENDIX: Gas compatibility tables

6.1 PDG-B and PDG-D

Models	Inerts, Nitrogen, Argon (50 bar)	Ar/CO ₂ (50 bar)	CO ₂ (50 bar)	CO (50 bar)	Air* (50 bar)	O ₂ (25 bar)	N ₂ O (25 bar)	H ₂ (50 bar)	C ₂ H ₂	C ₃ H ₈	C ₃ H ₆	C ₂ H ₄	CH ₄
Aluminium body													
PDG-B 50-1-2 PDG-B 50-4-3 PDG-B 50-10-4	Y	Y	Y	Y	Y	N	N	Y	N	N	N	N	N
Brass body													
PDG-D 50-10-3,5	Y	Y	Y	Y	Y	Y	Y	Y	N	N	N	N	N

* Air: compressed air not breathable

Models	Inerts, Nitrogen, Argon (25 bar)	Ar/CO ₂	CO ₂	CO (25 bar)	Air* (25 bar)	O ₂ (25 bar)	N ₂ O (25 bar)	H ₂ (25 bar)	C ₂ H ₂	C ₃ H ₈ (10 bar)	C ₃ H ₆	C ₂ H ₄	CH ₄ (25 bar)
Aluminium body													
PDG-D 25-10-12	Y	N	N	Y	Y	N	N	Y	N	Y	N	N	Y

6.2 PDG-B.S

Models	Inerts, Nitrogen, Argon (50 bar)	Ar/CO ₂	CO ₂	CO	Air* (50 bar)	O ₂ (25 bar)	N ₂ O	H ₂ (50 bar)	C ₂ H ₂	C ₃ H ₈ (10 bar)	C ₃ H ₆ (10 bar)	C ₂ H ₄ (50 bar)	CH ₄ (50 bar)
PDG-B.S 50-4-3 PDG-B.S 50-10-4	Y	N	N	N	Y	Y	N	Y	N	Y	Y	Y	Y

Models	Inerts, Nitrogen, Argon (25 bar)	Ar/CO ₂ (25 bar)	CO ₂ (25 bar)	CO (25 bar)	Air* (25 bar)	O ₂ (25 bar)	N ₂ O (25 bar)	H ₂ (25 bar)	C ₂ H ₂	C ₃ H ₈	C ₃ H ₆	C ₂ H ₄	CH ₄
PDG-D.S Pharma 25-10-12	Y	Y	Y	Y	Y	Y	Y	Y	N	N	N	N	N

6.3 PDG.A

Models	Inerts, Nitrogen, Argon	Ar/CO ₂	CO ₂	CO	Air*	O ₂	N ₂ O ₁	H ₂	C ₂ H ₂ (1,5 bar)	C ₃ H ₈	C ₃ H ₆	C ₂ H ₄	CH ₄
PDG-A 1,5-1-2 PDG-A 1,5-1-0,5	N	N	N	N	N	N	N	N	Y	N	N	N	N

In case of use with corrosive gas, check the compatibility between the equipment and the gas used.

7. DIMENSIONS

7.1 Points of use

L : 45 mm
 H : 145 mm
 D : 94 mm
 Ø1 : 40 mm

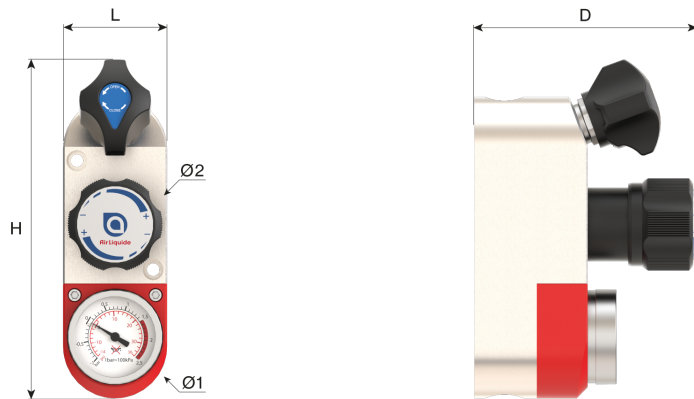

7.2 Plates

Support plate for one point of use

L : 80 mm
 L1 : 50 mm
 L2 : 15 mm
 H : 200mm
 H1 : 170 mm
 H2 : 140 mm
 H3 : 26 mm
 H4 : 80 mm
 P : 3 mm
 P1 : 30 mm
 Ø1 : 9 mm
 Ø2 : 20 mm

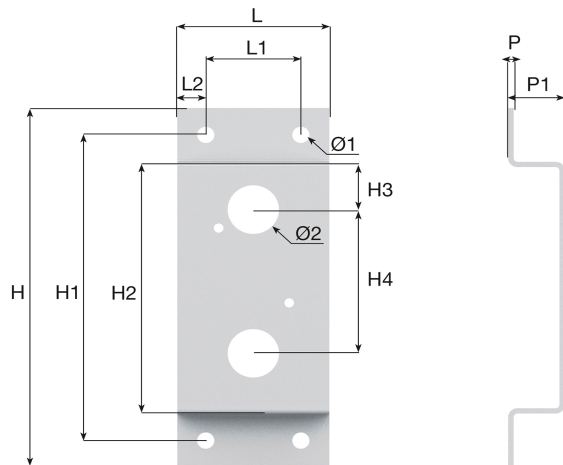

Support plate for two points of use

L : 160 mm
 L1 : 130 mm
 L2 : 15 mm
 L3 : 40 mm
 L4 : 80 mm
 H : 200mm
 H1 : 170 mm
 H2 : 140 mm
 H3 : 26 mm
 H4 : 80 mm
 P : 3 mm
 P1 : 30 mm
 Ø1 : 9 mm
 Ø2 : 20 mm

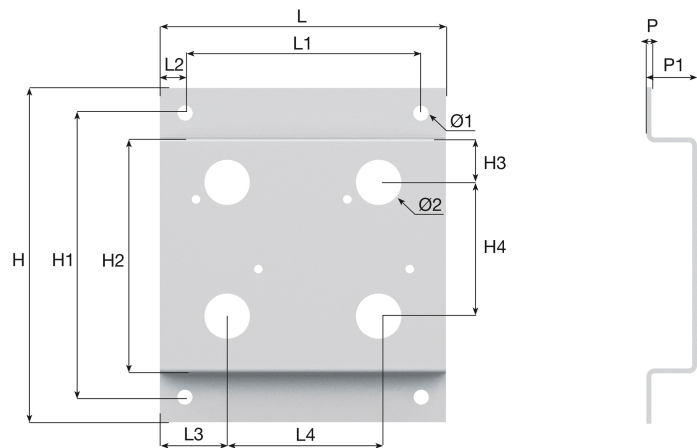

Support plate for three points of use

L : 240mm
L1 : 210 mm
L2 : 15 mm
L3 : 40 mm
L4 : 80 mm
H : 200mm
H1 : 170 mm
H2 : 140 mm
H3 : 26 mm
H4 : 80 mm
P : 3 mm
P1 : 30 mm
Ø1 : 9 mm
Ø2 : 20 mm

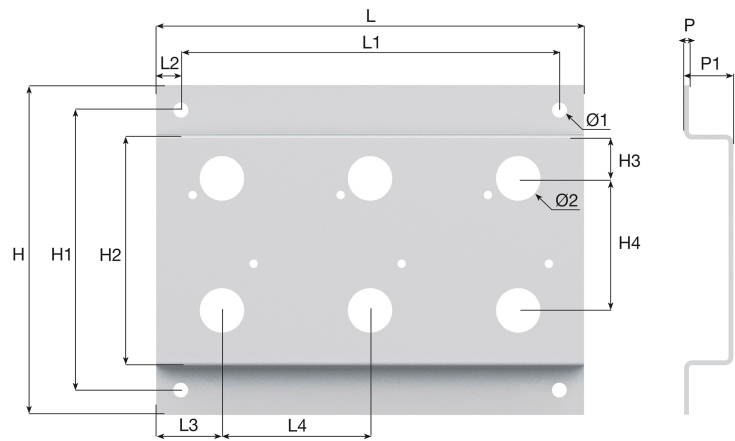

To contact us :

Air Liquide France Industrie

Service Client - Tél. +33(0)9 70 25 00 00

Courriel: **contact.alfi@airliquide.com**

Espace clients : **mygas.airliquide.fr**

www.airliquide.fr



Air Liquide France Industrie - Société Anonyme au capital de 72.267.600 Euros - Siège social : 6 rue Cognacq-Jay, 75007 Paris - RCS Paris 314 119 504.