	<b>Operating Instructions</b>  <b>IM &amp; LM Valves</b>	<b>OP 551</b> <b>Version: 0</b> <b>Date : Sept.2020</b> <b>Owner : SWE</b> <b>Language : EN</b>
---	--	---

## Operating Instructions for Shut-off valves LM-IM

Models
Valve IM 200-0,12
Valve LM 200-0,04

### Warning

To preserve the quality of our product throughout its usage in the best safety conditions, please read this manual carefully and strictly follow the instructions that it contains. Non-compliance with these instructions or modification of the product may result in serious accidents or bodily injuries. Air Liquide shall not be held responsible in case of non-approved usage of the product.

Air Liquide reserves the right to make all necessary modifications to the specifications described hereafter without notice.

# CONTENTS

<b>1. USE AND OPERATING PRINCIPLE</b>	<b>3</b>
1.1 Functions	3
1.2 Area of application	3
1.3 Operating principle and features	3
<b>2. AIR LIQUIDE COMMITMENTS</b>	<b>3</b>
2.1 Conformity	3
2.2 Cleaning	4
2.3 Inspections	4
2.4 Warranty	5
<b>3. ASSEMBLY-ACTIVATION</b>	<b>5</b>
3.1 Safety	5
3.2 Installation	6
3.2.1 Connection	6
3.2.2 Assembly of double ring connectors	6
3.2.3 Repeated assembly	7
<b>4. MAINTENANCE</b>	<b>8</b>
4.1 Troubleshooting	8
4.2 Maintenance	9
<b>5. APPENDIX</b>	<b>9</b>
5.1 Compatibility tables	9
5.2 Dimensions	9

# 1. USE AND OPERATING PRINCIPLE

## 1.1 Functions

The LM and IM valves are designed for the distribution of gases of high purity up to N60 including ALPHAGAZ 2 in laboratories.

## 1.2 Area of application

The LM valves are designed for use with high purity gases, except for corrosive gases.

The IM valves are designed for use with high purity gases and corrosive gases.

The maximum pressure varies according to the models and gases.

**IMPERATIVE** : check the gases compatibility of this equipment by referring to the "Gas Compatibility Table".

See in "APPENDIX".

## 1.3 Operating principle and features

The HP and IM valves are shut-off valves in Hastelloy C diaphragm. They are intended for pipes or panels.

- Operating temperature : - 20°C to + 50°C.
- Internal/external leak rate: <  $10^{-7}$  mbar.l/sec helium.
- Operating in the opposite direction from arrow = maximum differential pressure.
  - LM 200 and IM 200 = 50 bar

# 2. AIR LIQUIDE COMMITMENTS

## 2.1 Conformity

AIR LIQUIDE certifies that the equipment is manufactured, tested and controlled, in accordance with state of the art and AIR LIQUIDE rules.

It is the responsibility of the end user to ensure that such equipment is installed and used in accordance with the current regulations.

## **Directive 2014/68/EC: Pressurized equipment (PED)**

Technical requirements of Article 4§3 indicates that Pressure equipment and assemblies below or equal to the limits set out in points (a), (b) and (c) of paragraph 1 and in paragraph 2 respectively shall be designed and manufactured in accordance with the sound engineering practice of a Member State in order to ensure safe use.

Without prejudice to other applicable Union harmonisation legislation providing for its affixing, such equipment or assemblies shall not bear the CE marking referred to in Article 18.

By design, these equipment may integrate pressure relief valves or burst disks. In this case, those ones shall neither be CE marked according to paragraph 2 of annex II.

In all other cases, pressure relief valves and burst disks shall be CE marked.

## **Directive 2014/34/UE ATEX :**

The equipment is not in the scope defined in points a), b) et c) of the article of the ATEX Directive: consequently, they shall not bear the CE marking.

The equipment are not capable of causing an explosion through their own potential sources of ignition: then, they can be installed in ATEX zone 1 or 2, as far as respecting up to date regulations, rules, operating instructions, in accordance with the sound engineering practice are followed during installation and use.

Reminder: it belongs to the end user to define the ATEX zone.

## **REACH regulation (EC) n°1907/2006 :**

The valves are made of brass parts, essentially the body, which is a copper alloy with a lead content between 1% and 4% w/w.

As requested by art.33 of REACH Regulation (Registration, Evaluation and Authorisation of Chemicals) and with reference to current list of SVHC (substances of very high concern) available on ECHA website, we inform that lead may be present in a concentration above 0,1% w/w in our products made of brass.

Lead inclusion in the SVHC list in June 2018 does not modify the use conditions described in operating instructions.

Lead will not be released to the surrounding environment or the gas used during normal use.

After product end of life, the pressure reducers must be scrapped by an authorized metal recycler.

## **2.2 Cleaning**

Each equipment is subject to a grease removal and a high quality cleaning to preserve the purity of gas in the equipment as well as for use with oxygen for compatible equipment.

A suitable packaging protects the equipment against exterior pollutants during storage and transport.

Take care to avoid polluting the equipment during installation.

## **2.3 Inspections**

Equipment is inspected and has undergone a certified helium leak test prior to packing and dispatch.

## 2.4 Warranty

The guarantee time for all the equipment supplied by AIR LIQUIDE is 1 year, except for the equipment employing corrosive gases, for which the guarantee time is 6 months, provided that it is used in accordance with their purpose, and in compliance with the state of the art as described in "General chapter of the equipment catalogue".

The duration of this guarantee does not apply to consumable materials. Beyond this time, AIR LIQUIDE remains bond only to the legal guarantee.

During this guarantee time period :

- AIR LIQUIDE responsibility is strictly limited to the obligation to supply, repair or replace, as required, the good, with the exclusion of any material or immaterial damages, direct or indirect.
- AIR LIQUIDE repairs or replaces free of charge, excluding transport and packing expenses, all parts it has inspected and found faulty. In order to match this guarantee, AIR LIQUIDE reserves the right to modify the devices in place. Parts taken in part exchange, as an application of the guarantee, will be AIR LIQUIDE property.
- The guarantee does not apply to replacements or repairs that would result from normal wear of the devices and machines, from deteriorations or accidents originating from negligence, lack of surveillance or maintenance, or non conforming use of the equipment. Moreover, this guarantee will be terminated in the case where the customer would perform himself repairs or modifications to the sold equipment. The payable repair of used equipment includes no guarantee. The transport cost for equipment or repaired or replaced parts are chargeable to the customer, as in case of repair on the installation area, the travel and stay expenses of AIR LIQUIDE agents or delegates, according to its tariff then in force.
- AIR LIQUIDE responsibility resulting from the sale is expressly limited to the guarantee.

## 3. ASSEMBLY-ACTIVATION

### 3.1 Safety

Unless expressly and specifically otherwise specified, AIR LIQUIDE guarantees the equipment only for the use for which it was designed and not the use for which the customer may intend it.

The user has to strictly comply with rules, regulations and specifications in force. He is responsible in particular for corporal, material, direct or indirect accidents and damages an inappropriate assembly, a modification or a lack of maintenance may cause.

Use only the equipment compatible with the type of gas employed, pressures and flows wished.

- Respect the pressures maximum according to gases (see chapter "compatibility")
- Use only equipment in perfect condition.

- Never act on a device or a line under pressure.
- Open slowly and progressively the cylinder or bundle cocks, and all the valves (in case of oxygen, you will thus avoid the effects of excessive heatings by compression).
- Maintain circuitry tightness.
- Do not grease the equipment (risk of explosion).
- Respect cleanliness of this equipment. The particle penetrations at the time of miscellaneous handling are at the origin of most failures.
- Never smoke in the vicinity (risk of explosion).
- Never heat, or bring a flame near the equipment.
- The valves are designed to be associated with other accessories. Assembling such accessories should be performed by qualified personnel.
- Inquire about gas use cautions consulting security notices and security data forms.
- For piping or equipments designed to acetylene :

No using copper or alloys with more than 70% copper.

The pressure must be limited to 1.5 bar and the flowrate must not exceed 30 m/s in the pipes. The internal diameter of these pipes should be less than 15 mm (risk of explosion).

- The equipment must be left out of reach of children.
- Comply with indications and marking on the equipment.
- It is wished to name a gas and material responsible on the exploiting site "who will supervise the respects of safety rules".

## 3.2 Installation

Every valve is delivered wedged in wrapping to protect it during transport and handling.

After opening the wrapping, ensure yourself that the material did not undergo any visible damage.

Check that the content is in accordance with your order and does correspond to your needs. In the opposite case, immediately do the usage reserves and inform your AIR LIQUIDE correspondent.

### 3.2.1 Connection

Valves of with ports inlet and outlet G  $\frac{3}{8}$  AL type : to screw fittings with couple to the tightening of 3.5mN.

Valves with ports inlet and outlet double ring GYROLOK machined in the body.

- Valves LM (brass) : set only a copper tube.
- Valves IM (stainless steel) : set on copper tube or in stainless steel.

### 3.2.2 Assembly of double ring connectors

Connector pre-assembled by hand :

- After cutting the tube square and removing all burrs (preferably use a tube cutter), pre-assemble the nut and ferrules in the order shown in the figure.
- Insert the tube inside the connector until it is abutting the body. Tighten the nut completely by hand.
- Complete tightening, with a wrench, by 1  $\frac{1}{4}$  turn.

### 3.2.3 Repeated assembly

The pipe can be disconnected and then reconnected.

Use the following procedure:

- Insert the tube, with its seal into the union body and finger-tighten the nut.
- Turn the nut with a wrench and stop when the torque required suddenly increases.

This is possible to set up stainless steel unions on copper tubes, but **NEVER** brass unions on stainless steel tubes.

## 4. MAINTENANCE

### 4.1 Troubleshooting

Default	Cause	Remedy
Mounting impossible	Connections cannot be mount	Verify the compatibility of gases, inlet and outlet
	Damaged connections	Replace the valve
Insufficient flow rate	Under-dimensional equipment	Contact Air Liquide
	Downstream device not operational	Change the device
Gas leak	Tightness default	Close the cylinder valve and replace the safety valve

### 4.2 Maintenance

Although highly robust, valves need periodical checking. This requires a number of precautions and must only be done by our departments or our approved representatives.

The interval between checks mainly depends on how the valve is used (intensively, normally or only occasionally) and must be defined by the sales manager in agreement with the user. The period must never exceed 5 years.

If an operating problem (leak, jamming closed) occurs, return the valve for overhaul.

**Never disassembly a component. In fact a defective reassembly, risks to involve the no operation.**



## 5. APPENDIX

### 5.1 Compatibility tables

Valves	N <sub>2</sub>	CO <sub>2</sub>	CO	Air*	O <sub>2</sub>	N <sub>2</sub> O	H <sub>2</sub>	C <sub>2</sub> H <sub>2</sub>	C <sub>3</sub> H <sub>8</sub>	C <sub>3</sub> H <sub>6</sub>	C <sub>2</sub> H <sub>4</sub>	CH <sub>4</sub>	NH <sub>3</sub>
Valve IM 200-0,12	Y (200 bar)	Y (200 bar)	Y (200 bar)	Y (200 bar)	Y (25 bar)	Y (25 bar)	Y (200 bar)	Y (1,5 bar)	Y (200 bar)	Y (200 bar)	Y (200 bar)	Y (200 bar)	Y (200 bar)
Valve LM 200-0,04	Y (200 bar)	Y (200 bar)	N	Y (200 bar)	Y (200 bar)	Y* (50 bar)	Y (200 bar)	N	Y (200 bar)	Y (200 bar)	Y (200 bar)	Y (200 bar)	N

\* with compression fittings

### 5.2 Dimensions

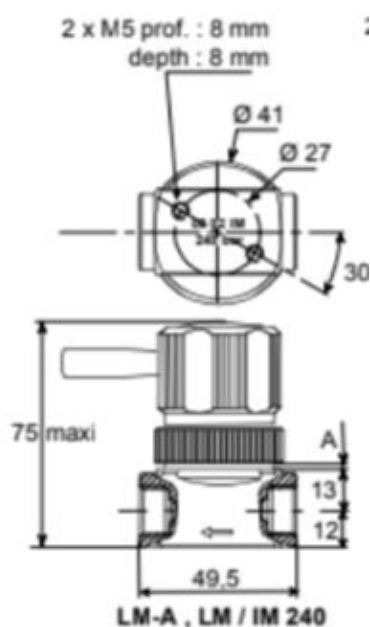
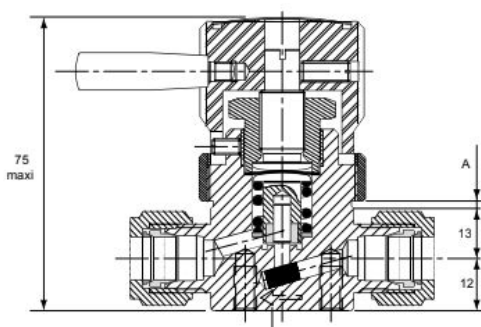

To contact us :

**Air Liquide France Industrie**

Service Client - Tél. (33) 1 -09 70 25 00 00

Courriel: **contact.alfi@airliquide.com**

Espace clients : **mygas.airliquide.fr**

[www.airliquide.fr](http://www.airliquide.fr)



Air Liquide France Industrie - Société Anonyme au capital de 72.267.600 Euros - Siège social : 6 rue Cognacq-Jay, 75007 Paris - RCS Paris 314 119 504.