



Operating Instructions Pigtails

OP 1060
Version : 0
Date : June 2022
Owner : NEC
Language : EN

Operating Instructions

Pigtails

Models
PIGTAIL SS TYPE C/B4
PIGTAIL SS TYPE F (NF)/ A1
LYRE SS TYPE E (NF)

Warning

To preserve the quality of our product throughout its usage in the best safety conditions, please read this manual carefully and strictly follow the instructions that it contains. Non-compliance with these instructions or modification of the product may result in serious accidents or bodily injuries. Air Liquide shall not be held responsible in case of non-approved usage of the product. Air Liquide reserves the right to make all necessary modifications to the specifications described hereafter without notice.

CONTENTS

1. FIELD OF USE AND CHARACTERISTICS	3
1.1 Functions	3
1.2 Technical characteristics	3
1.3 Gas compatibility	3
2. AIR LIQUIDE COMMITMENTS	3
2.1 Conformity	3
2.2 Warranty	4
2.3 Inspections	4
2.4 Cleaning	4
3. SAFETY	5
4. ASSEMBLY AND INSTALLATION	5
4.1 Precautions before assembly	5
4.2 Assembly	6
4.3 Activation	6
5. MAINTENANCE	7
5.1 Troubleshooting	7
5.2 Maintenance	7
6. APPENDIX	7
Drawings	7

1. FIELD OF USE AND CHARACTERISTICS

1.1 Functions

Pigtails allow to :

- Connect 200 or 300 bar cylinders to a gas manifold.
- Transfer a gas by preserving its purity. Pigtails are designed for the use of pure gases and mixtures with purity < N60 thus Alphagaz 1 and 2 and industrial gases.

1.2 Technical characteristics

Warranty tightness : 10⁻⁸ mbar.l/s helium.

Operating temperature : from -20°C to + 60°C.

1.3 Gas compatibility

IMPERATIVE : check the gases compatibility of this equipment.

2. AIR LIQUIDE COMMITMENTS

AIR LIQUIDE certifies that the equipment is manufactured, tested and controlled, in accordance with state of the art and AIR LIQUIDE rules.

It is the responsibility of the end user to ensure that such equipment is installed and used in accordance with the current regulations.

2.1 Conformity

Directive 2014/68/CE : Pressurized equipment (PED)

Technical requirements of Article 4§3 indicates that Pressure equipment and assemblies below or equal to the limits set out in points (a), (b) and (c) of paragraph 1 and in paragraph 2 respectively shall be designed and manufactured in accordance with the sound engineering practice of a Member State in order to ensure safe use.

Without prejudice to other applicable Union harmonisation legislation providing for its affixing, such equipment or assemblies shall not bear the CE marking referred to in Article 18.

By design, these equipment may integrate pressure relief valves or burst disks. In this case, those ones shall neither be CE marked according to paragraph 2 of annex II.

In all other cases, pressure relief valves and burst disks shall be CE marked.

Directive 2014/34/UE ATEX :

The equipment is not in the scope defined in points a), b) et c) of the article of the ATEX Directive: consequently, they shall not wear the CE marking.

The equipment are not capable of causing an explosion through their own potential sources of ignition: then, they can be installed in ATEX zone 1 or 2, as far as respecting up to date regulations, rules, operating instructions, in accordance with the sound engineering practice are followed during installation and use.

Reminder: it belongs to the end user to define the ATEX zone.

REACH Regulation (CE) n°1907/2006 :

The pressure reducers are made of brass parts, essentially the body, which is a copper alloy with a lead content between 1% and 4% w/w.

As requested by art.33 of REACH Regulation (Registration, Evaluation and Authorisation of Chemicals) and with reference to current list of SVHC (substances of very high concern) available on ECHA website, we inform that lead may be present in a concentration above 0,1% w/w in our products made of brass.

Lead inclusion in the SVHC list in June 2018 does not modify the use conditions described in operating instructions.

Lead will not be released to the surrounding environment or the gas used during normal use.

After product end of life, the pressure reducers must be scrapped by an authorized metal recycler.

2.2 Warranty

The warranty period for equipment supplied by Air Liquide is one year, covering faulty material or workmanship during manufacture. The warranty does not cover packing and return transport costs.

Warranty is not valid on deterioration resulting from incorrect or improper use, arbitrary reparations, use of spare parts which are not recommended by Air Liquide or from the none respect of this operating instruction.

For more information, refer to the general sales conditions of AIR LIQUIDE.

2.3 Inspections

Each equipment is inspected and has undergone a sealing test before packing.

2.4 Cleaning

Each equipment is subject to a grease removal and a high quality cleaning to preserve the purity of gas in the equipment as well as for use with oxygen for compatible equipment.

A suitable packaging protects the equipment against exterior pollutants during storage and transport.

Take care to avoid polluting the equipment during installation.

3. SAFETY

First of all, it is essential to read and respect the safety instructions described in the document "General Safety Instructions" delivered with the product.

For safety reasons the inlet fitting and the seal are specific to a gas or a mixture family, they are so designed to avoid any connection mistake. Refer to the gas compatibility table.

NEVER use the pigtails for an application or a gas different than the one for which it is intended.

- Before connecting the pigtail to avoid any risk of falling cylinders etc., ensure that :
 - cylinders are safely secured with adequate restraints,
 - bundles are well placed on a plane and horizontal surface,
 - the location of the cylinders is sufficiently well ventilated.

The delivered equipment is totally without any grease marks, be careful not to pollute it.

- Never disconnect a pigtail if :
 - the cylinder or bundle valve is not closed,
 - or the pigtail is under pressure.

Never tighten a fitting under pressure. In all cases, open and close the valves SLOWLY. Never attempt to repair a pigtail. In case of problem, close the cylinder valve, purge the pigtail and replace it by a complete new assembly.

4. ASSEMBLY AND INSTALLATION

4.1 Precautions before assembly

After opening the packaging, check that the equipment is not damaged and that the contents correspond to the delivery notes accompanying the equipment.

Because pigtails are sensible to various mechanical constraints, the activation of these equipment has to respect a certain number of Air Liquide recommendations such as :

- Act cleanly in order not to pollute,
- avoid the twistings,
- avoid or limit the "water hammer".

4.2 Assembly

Connect the two extremities of the pigtails, one side to the cylinder, the other on to the gas manifold (Change-over or panel) :

- Gas manifold side : key tightening.
- Cylinder side :
 - Key tightening in the case of flat seals or in case of metal-metal tightness.
 - Hand tightening in the case of O-rings.

4.3 Activation

- Slowly open the cylinder valve and in two steps :
 - Slowly and partially open the cylinder valve and wait for the balancing of the pressures.
 - Close the valve and check on the high-pressure manometer of the gas manifold that the pressure does not change.
 - Open again the valve. Slowly proceed to avoid the "water hammer".
- If necessary, check the tightness of the assembly (upstream circuit closed).
The tightness of each pigtail, being controlled in factory, it remains nevertheless necessary to check the tightness of the connections. NEVER tighten a connection under pressure.

5. MAINTENANCE

5.1 Troubleshooting

Default	Cause	Remedy
Mounting impossible	Connections cannot be mounted	Verify the compatibility of gases, inlet and outlet
	Damaged connections	Change the reducer
Gas leak	Tightness default	Close the cylinder valve and replace the reducer

5.2 Maintenance

Pigtails require a periodic check.

The periodicity of this check depends on the use conditions of the pigtails (type of gas, environment...). The maximum pigtail lifetime is 5 years.

- Verify the general state of the pigtail.
- Verify the state of seals and threads.
- Control the level of corrosion of the various components.
- Change seals each time you change cylinders.

6. APPENDIX

Drawings

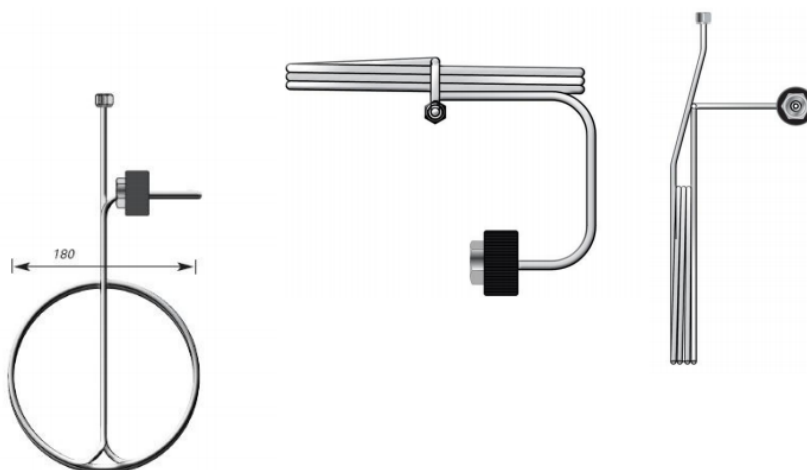

To contact us:

Air Liquide United Kingdom

- Air Liquide UK Limited, Station Road, Coleshill, Birmingham B46 1JY.
- Tel: +44 (0)1782 822061 Fax: +44 (0)1782 826850
- email: specgas.aluk@airliquide.com

