	<p><b>Operating Instructions</b> Line reducers DCn range</p>	<p><b>OP 212</b> <b>Version : 0</b> <b>Date : June 2022</b> Owner : NEC Language : EN Manufacturer: NT0143</p>
---	--	--

# Operating Instructions

## Line reducers for industrial gases

### DCn range

Modèles DCn
DCn100
DCn300, DCn300-FOOD
DCn500
DCn800, DCn800 FOOD
DCn800-30

**Warning**

To preserve the quality of our product throughout its usage in the best safety conditions, please read this manual carefully and strictly follow the instructions that it contains. Non-compliance with these instructions or modification of the product may result in serious accidents or bodily injuries. Air Liquide shall not be held responsible in case of non-approved usage of the product. Air Liquide reserves the right to make all necessary modifications to the specifications described hereafter without notice.

# SUMMARY

<b>1. FIELD OF USAGE</b>	<b>3</b>
1.1 Functions	3
1.2 Usage	3
<b>2. AIR LIQUIDE COMMITMENTS</b>	<b>4</b>
2.1 Conformity	4
2.2 Cleaning	5
2.3 Inspections	5
2.4 Warranty	5
<b>3. ASSEMBLY-ACTIVATION</b>	<b>6</b>
3.1 Safety	6
3.2 Precautions before assembly	6
3.3 Assembly on pipe	6
3.4 Mounting on panel	7
3.5 Start up	7
3.5.1 Preliminary controls	7
3.5.2 Start up of the pipeline system	7
<b>4.MAINTENANCE</b>	<b>8</b>
4.1 Defaults- Remedies	8
4.2 Maintenance	8
4.3 Disposal and recycling	9
<b>5.APPENDIX : Gas compatibility tables</b>	<b>10</b>
5.1 DCn100	10
5.2 DCn300	10
5.3 DCn500	10
5.4 DCn800	11
5.5 DCn800-30-800	11
<b>6.APPENDIX : Dimensions</b>	<b>12</b>
6.1 Drawings DCn100 et DCn300	12
6.2 Drawings DCn500 DCn500-TBP et DCn800	13
6.3 Drawings DCn800-30 bar	14

# 1. FIELD OF USAGE

## 1.1 Functions

The line regulators allow you to :

- to reduce the pressure as a second stage,
- to regulate and maintain stability of outlet pressure,
- to preserve the gas purity.

The line regulators are designed for implementation of industrial gases.

Specific regulators which are dedicated to Food and beverage applications have a specific "Food" indication on their designation and a Food logo marking. They can only be used with *ALIGAL™* gas products.

The Line Regulators are used as a 2nd stage pressure reducer on the pipe network.

**WARNING !** The line regulators should not be used as shut-off valves.

## 1.2 Usage

As the line regulators are designed to control the pressure in an installation, the handwheel is not supposed to be operated as often as a pressure reducer for gas cylinders.

Usually, the pressure is set at the start up and may be adjusted only if the pressure has changed, that is to say quite rarely.

If the frequency of handwheel operating is higher, a dedicated pressure reducer should be selected.

Operating temperature : -20°C to + 60° C

## **2. AIR LIQUIDE COMMITMENTS**

### **2.1 Conformity**

AIR LIQUIDE certifies that the equipment is manufactured, tested and controlled, in accordance with state of the art and AIR LIQUIDE rules.

It is the responsibility of the end user to ensure that such equipment is installed and used in accordance with the current regulations

#### **PED Directive 2014/68/EC: Pressurized equipment**

Technical requirements of Article 4§3 indicates that Pressure equipment and assemblies below or equal to the limits set out in points (a), (b) and (c) of paragraph 1 and in paragraph 2 respectively shall be designed and manufactured in accordance with the sound engineering practice of a Member State in order to ensure safe use.

Without prejudice to other applicable Union harmonisation legislation providing for its affixing, such equipment or assemblies shall not bear the CE marking referred to in Article 18.

By design, these equipment may integrate pressure relief valves or burst disks. In this case, those ones shall neither be CE marked according to paragraph 2 of annex II.

In all other cases, pressure relief valves and burst disks shall be CE marked.

#### **ATEX Directive 2014/34/EC**

The equipment is not in the scope defined in points a), b) et c) of the article of the ATEX Directive: consequently, they shall not wear the CE marking.

The equipment is not capable of causing an explosion through their own potential sources of ignition: then, they can be installed in ATEX zone 1 or 2, as far as respecting up to date regulations, rules, operating instructions, in accordance with the sound engineering practice are followed during installation and use.

Reminder: it belongs to the end user to define the ATEX zone.

#### **REACH regulation (EC) n°1907/2006**

The pressure reducers are made of brass parts, essentially the body, which is a copper alloy with a lead content between 1% and 4% w/w.

As requested by art.33 of REACH Regulation (Registration, Evaluation and Authorisation of Chemicals) and with reference to current list of SVHC (substances of very high concern) available on ECHA website, we inform that lead may be present in a concentration above 0,1% w/w in our products made of brass.

Lead inclusion in the SVHC list in June 2018 does not modify the use conditions described in operating instructions.

Lead will not be released to the surrounding environment or the gas used during normal use.

After product end of life, the pressure reducers must be scrapped by an authorized metal recycler.

#### **FOOD regulation (EC) n°1935/2004**

The AL equipment enhancing the term "FOOD" in their designation are specifically designed for use with food gases used for food and beverage applications. They are compliant with Regulation EC 1935/2004 which requires that packaging and articles intended to be in contact with foodstuffs are to be manufactured in compliance with good manufacturing practices and standard operating procedures.

Thus, under normal or foreseeable conditions of use, , no transfer of contaminants, eg, metal elements, to food in quantities that could endanger human health, modify food composition or deteriorate organoleptic characteristics is expected.

Nethertheless, the end-user must check the compliance with an eventual national regulation.

Articles for food usage has a Food logo marking.

For traceability purposes, the batch number is written on each article and AL can perform a batch recall, as requested by its Quality management system.



## **2.2 Cleaning**

Each equipment is subject to a grease removal and a high quality cleaning to preserve the purity of gas in the equipment as well as for use with oxygen for compatible equipment.

A suitable packaging protects the equipment against exterior pollutants during storage and transport. Take care to avoid polluting the equipment during installation.

## **2.3 Inspections**

Each equipment is inspected and has undergone a sealing test before packing.

## **2.4 Warranty**

The warranty period for equipment supplied by Air Liquide is one year, covering faulty material or workmanship during manufacture. The warranty does not cover packing and return transport costs.

Excluded from warranty: seals and relief valves. These components are submitted to a natural wear.

Warranty is not valid on deterioration resulting from incorrect or improper use, use of spare parts which are not recommended by Air Liquide or from the none respect of this operating instruction.

For more information, refer to the general sales conditions of Air Liquide.

### 3. ASSEMBLY-ACTIVATION

#### 3.1 Safety

First of all, it is essential to read and respect the safety instructions described in the document "General Safety Instructions" delivered with the product.

NEVER dismantle a component of the regulator in the High Pressure part, especially the cylinder inlet fitting.

#### 3.2 Precautions before assembly

After opening the packaging, check that the equipment is not damaged and that the contents correspond to the accompanying delivery notes.

- During assembly, it is important to take extreme care to ensure cleanliness and avoid contamination.
- To install the equipment, select a ventilated area, protected from the effects of bad weather.

#### 3.3 Assembly on pipe

- Check the cleanliness of the inlet and outlet ports and the suitability of the selected connections with the pipe.
- Check the presence of the filter and seal at the inlet.
- Unless your filter consists of a complete set (crimped sieve), make sure that the filter is in the right position (see drawing).
- Respect the direction of the flow shown by arrows.
- We recommend ensuring the gas tightness of the inlet connection with the seal and the filter supplied (tightening torque required between 30 and 50 N.m).

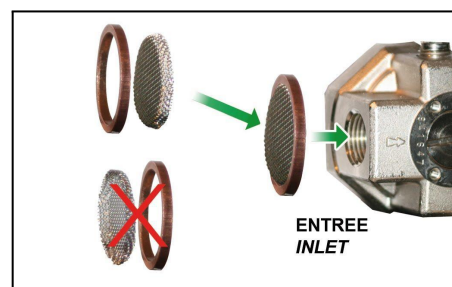
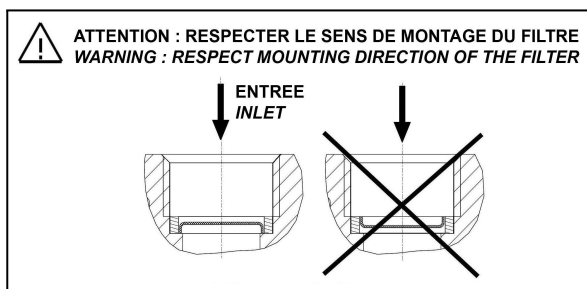

#### Recommandations :

- Install a relief valve on the pipe to protect installation, following risk analysis.
- The installation owner is responsible for the safety relief valve to be installed for its application protection.

### 3.4 Mounting on panel

The drilling diameter is indicated in Appendix.

#### a) DCn100 / Dcn300:

- Take the grey plastic cap out of the top of the handwheel.
- Unscrew the fastening screw of the handwheel by means of a screwdriver.  
Be careful not to lose the washer.
- Remove the handwheel.
- Place the regulator on the panel.
- Fasten the regulator by means of the lock nut.
- Screw again the handwheel.

NB: The DCn100 and DCn300 can also be mounted on a panel thanks to the 3 inlet threads located in the body.

#### b) DCn500 / DCn800 / DCn500TBP :

- Unscrew the lock nut of the handwheel.
- Unscrew the handwheel.
- Place the regulator on the panel.
- Fasten the regulator by means of the lock nut.
- Screw again the handwheel into position.

In order to fix the regulators to a panel without any float, the thickness of the panel must be:

- *at least 1,5 mm thick for the DCn100 et DCn300,*
- *and at least 2 mm thick for the DCn500, DCn500TBP, DCn800.*

### 3.5 Start up

#### 3.5.1 Preliminary controls

Turn the regulator off by unscrewing the handwheel.

Open the line upstream.

Carry on flushing so as to drain possible impurities.

Check that there is no leak at the inlet connection (with a non-fat foam reagent for example).

Check that there is no leak at the regulating valve. The outlet pressure gauge should remain at zero. If no leaks are detected, the regulator is ready for start-up.

#### 3.5.2 Start up of the pipeline system

Shut-off the line downstream of the regulator.

Adjust the downstream pressure by turning the handwheel clockwise.

Wait a few seconds and check that the adjusted downstream pressure is stable (in case of pressure increase indicated by the gauge, the regulator should be serviced).

Check that there is no leak at the outlet connection (with a non-fat foam reagent for example).

Open the line downstream and readjust, if necessary, the formerly adjusted pressure.

Caution:

- . To protect the gauge, the operating pressure should not exceed 3/4 of the gauge graduation.
- . In the absence of use for a long period, shut-off the line upstream. In any case, a regulator should never be used as a shut-off valve

## 4.MAINTENANCE

### 4.1 Defaults- Remedies

Default	Cause	Remedy
Mounting impossible	Connections can not be mounted	check inlet and outlet fittings and thread
	Damaged connections	Replace the regulator
Insufficient flow rate	Cross section of passage limited by a valve	Open the valve
	Under-dimensional equipment	Contact Air Liquide
	Downstream device not operational	Change the device
Gas leak	Tightness default	Change the device
Rise of the outlet pressure	Leakage at the poppet	
Unstable outlet pressure or frosting	Working temperature too low	Close the gas source. Bring back the equipment temperature above 0 °C
	Gas used is argon (Ar), carbon dioxide (CO <sub>2</sub> ) or nitrous oxide (N <sub>2</sub> O)	Respect the max. flow rate of the regulator.
	Flow rate too high	Limit the flow by a valve or a calibrated orifice
Vibrations	low rate to high	Limit the flow by a valve or a calibrated orifice
	Presence of valve with quick opening on the downstream pipe	Slow down the valve opening
Handwheel jamming	excessive frequency of operation	Replace the line regulator by an adapted regulator for high frequency operation

### 4.2 Maintenance

In normal condition of use, discarding after 10 years in working.

### 4.3 Disposal and recycling

At the end of the equipment's useful life or when it is impossible to repair it, it is essential to respect the local regulations for recycling / disposal of our equipment

To prevent reuse, these products must be unsuitable for use.

In accordance with EU Directive 2018/851 on waste, the owner of the equipment ensures that when recovery is not carried out in accordance with article 10, the waste will be subjected to safe disposal operations that comply with the provisions of article 13 on the protection of human health and the environment.

The licensee must take steps to promote high quality recycling and, to this end, must establish separate waste collections when technically, environmentally and economically feasible and adequate to meet the quality standards required by the relevant recycling sectors.

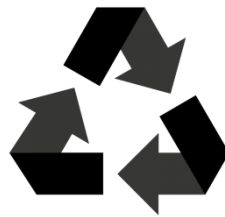
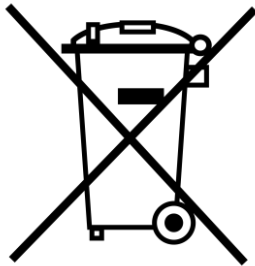

## 5.APPENDIX : Gas compatibility tables

### 5.1 DCn100

Models	Inerts Nitrogen (50 bar)	Ar & Ar/CO <sub>2</sub> (50 bar)	CO <sub>2</sub> (50 bar)	CO	Air * (50 bar)	O <sub>2</sub> (50 bar)	N <sub>2</sub> O (50 bar)	H <sub>2</sub> (50 bar)	C <sub>2</sub> H <sub>2</sub> (1,5 bar)	C <sub>3</sub> H <sub>8</sub>	C <sub>3</sub> H <sub>6</sub>	C <sub>2</sub> H <sub>4</sub>	CH <sub>4</sub> (50 bar)
DCn100 AG 50-2,6-30													
DCn100 AG 50-6-57	Y	Y	Y	N	Y	Y	Y	Y	N	N	N	N	Y
DCn100 AG 50-18-125													
DCn100 C <sub>2</sub> H <sub>2</sub> 1,5-1,4-5	N	N	N	N	N	N	N	N	Y	N	N	N	N

Line reducer DCn100-C<sub>2</sub>H<sub>2</sub> is dedicated **only** to acetylene application C<sub>2</sub>H<sub>2</sub>.

\* air: compressed air ( not breathable )

B.A : breathable air

### 5.2 DCn300

Models	Inerts Nitrogen (50 bar)	Ar & Ar/CO <sub>2</sub> (50 bar)	CO <sub>2</sub> (50 bar)	CO	Air * (50 bar)	O <sub>2</sub> (50 bar)	N <sub>2</sub> O (50 bar)	H <sub>2</sub> (50 bar)	C <sub>2</sub> H <sub>2</sub> (1,5 bar)	C <sub>3</sub> H <sub>8</sub> (10 bar)	C <sub>3</sub> H <sub>6</sub> (10 bar)	C <sub>2</sub> H <sub>4</sub> (50 bar)	CH <sub>4</sub> (50 bar)
DCn300 AG 50-2,6-80													
DCn300 AG 50-6-150	Y	Y	Y	N	Y	Y	Y	Y	N	N	N	N	Y
DCn300 AG 50-18-400													
DCn300 AG 50-40-600													
DCn300 C <sub>2</sub> H <sub>2</sub> 1,5-1,4-12	N	N	N	N	N	N	N	N	Y	N	N	N	N
DCn300 Flamal 50-7-50	N	N	N	N	N	N	N	N	N	Y	Y	Y	Y

\* air: compressed air ( not breathable )

B.A : breathable air

### 5.3 DCn500

Models	Inerts Nitrogen (50 bar)	Ar & Ar/CO <sub>2</sub> (50 bar)	CO <sub>2</sub> (50 bar)	CO	Air * (50 bar)	O <sub>2</sub> (50 bar)	N <sub>2</sub> O (50 bar)	H <sub>2</sub> (50 bar)	C <sub>2</sub> H <sub>2</sub>	C <sub>3</sub> H <sub>8</sub>	C <sub>3</sub> H <sub>6</sub>	C <sub>2</sub> H <sub>4</sub>	CH <sub>4</sub> (50 bar)
DCn500 AG 50-2,6-180													
DCn500 AG 50-6-450	Y	Y	Y	N	Y	Y	Y	Y	N	N	N	N	Y
DCn500 AG 50-12-750													
DCn500 TBP 10-0,7-100													

\* air: compressed air ( not breathable )

B.A : breathable air

## 5.4 DCn800

Models	Inerts Nitrogen (50 bar)	Ar & Ar/CO <sub>2</sub> (50 bar)	CO <sub>2</sub> (50 bar)	CO	Air * (50 bar)	O <sub>2</sub> (50 bar)	N <sub>2</sub> O (50 bar)	H <sub>2</sub> (50 bar)	C <sub>2</sub> H <sub>2</sub> (1,5 bar)	C <sub>3</sub> H <sub>8</sub> (10 bar)	C <sub>3</sub> H <sub>6</sub> (10 bar)	C <sub>2</sub> H <sub>4</sub> (50 bar)	CH <sub>4</sub> (50 bar)
DCn800 AG 50-2,6-200													
DCn800 AG 50-6-600	Y	Y	Y	N	Y	Y	Y	Y	N	N	N	N	Y
DCn800 AG 50-12-900													
DCn800 Flamal 50-7-50	N	N	N	N	N	N	N	N	N	Y	Y	Y	Y

\* air: compressed air ( not breathable )

B.A : breathable air

## 5.5 DCn800-30-800

Models	Inerts Nitrogen (50 bar)	Ar & Ar/CO <sub>2</sub> (50 bar)	CO <sub>2</sub> (50 bar)	CO	Air * (50 bar)	O <sub>2</sub> (50 bar)	N <sub>2</sub> O (50 bar)	H <sub>2</sub> (50 bar)	C <sub>2</sub> H <sub>2</sub> (1,5 bar)	C <sub>3</sub> H <sub>8</sub> (10 bar)	C <sub>3</sub> H <sub>6</sub> (10 bar)	C <sub>2</sub> H <sub>4</sub> (50 bar)	CH <sub>4</sub> (50 bar)
DCn800 AG 50-30-800	Y	Y	Y	N	Y	Y	N	Y	N	N	N	N	N

\* air: compressed air ( not breathable )

## 6.APPENDIX : Dimensions

### 6.1 Drawings DCn100 et DCn300

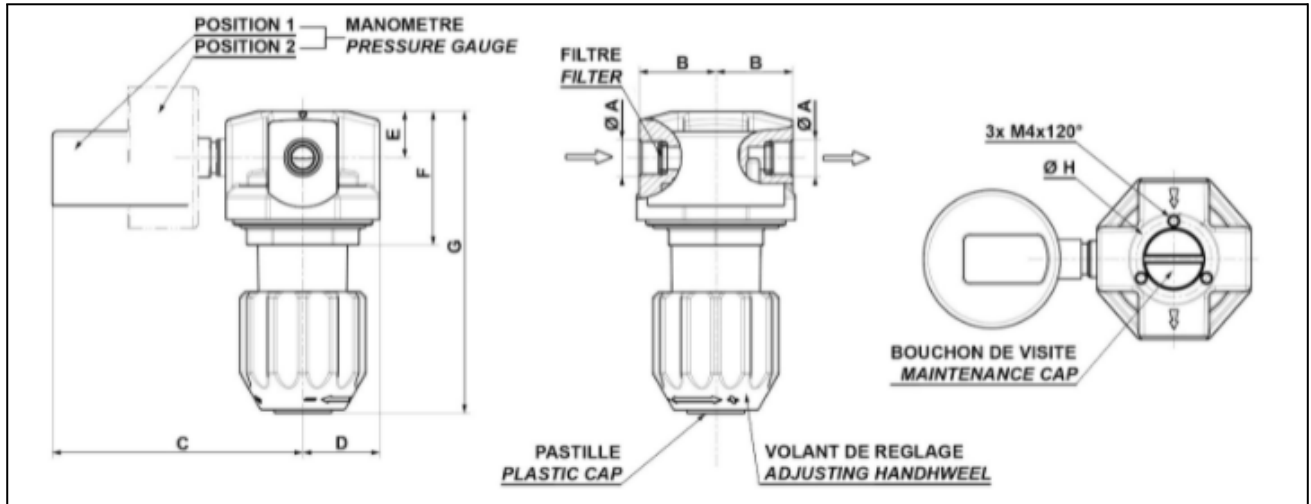

Models	ØA	B	C	D	E	F	G	ØH	Ø Drilling
<b>DCn100</b>	G1/4"	27,5	88,5	27,5	16,5	47	109	27	33
<b>DCn300</b>	G1/2"	32,5	91	32,5	18	59	123	29	

## 6.2 Drawings DCn500 DCn500-TBP et DCn800

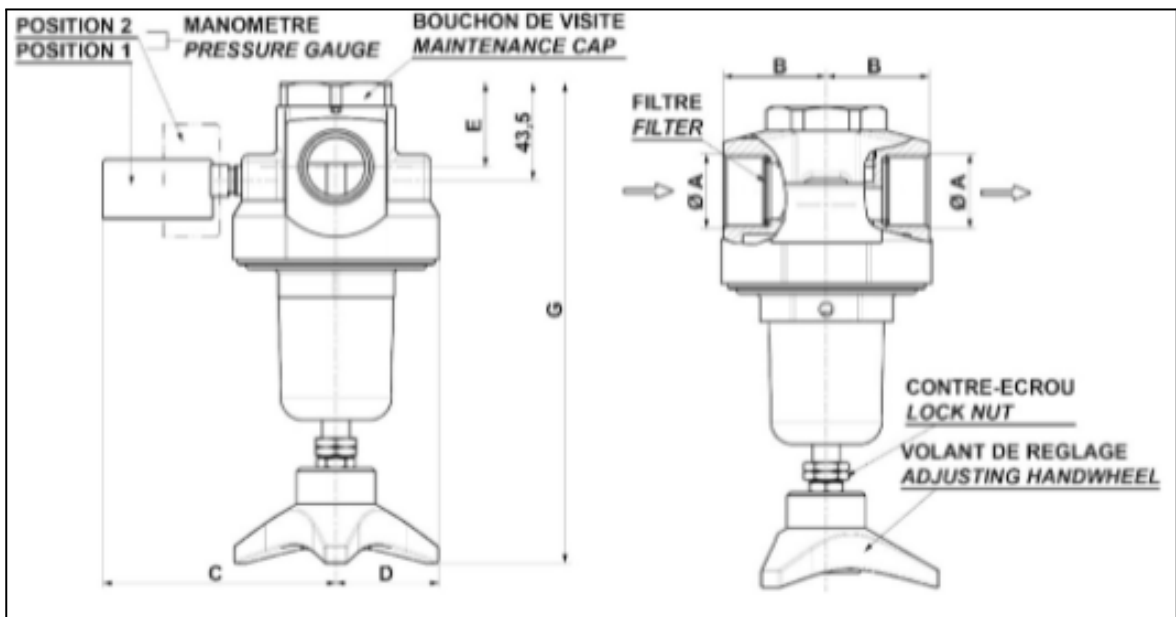

MODELS	ØA	B	C	D	E	F	G	ØH	Ø Drilling
<b>DCn500</b>	G3/4"	46	103	46	37,5	-	214	-	51
<b>DCn500 TBP</b>									
<b>DCn800</b>	G1"	46	103	46	37,5	-	214	-	

### 6.3 Drawings DCn800-30 bar

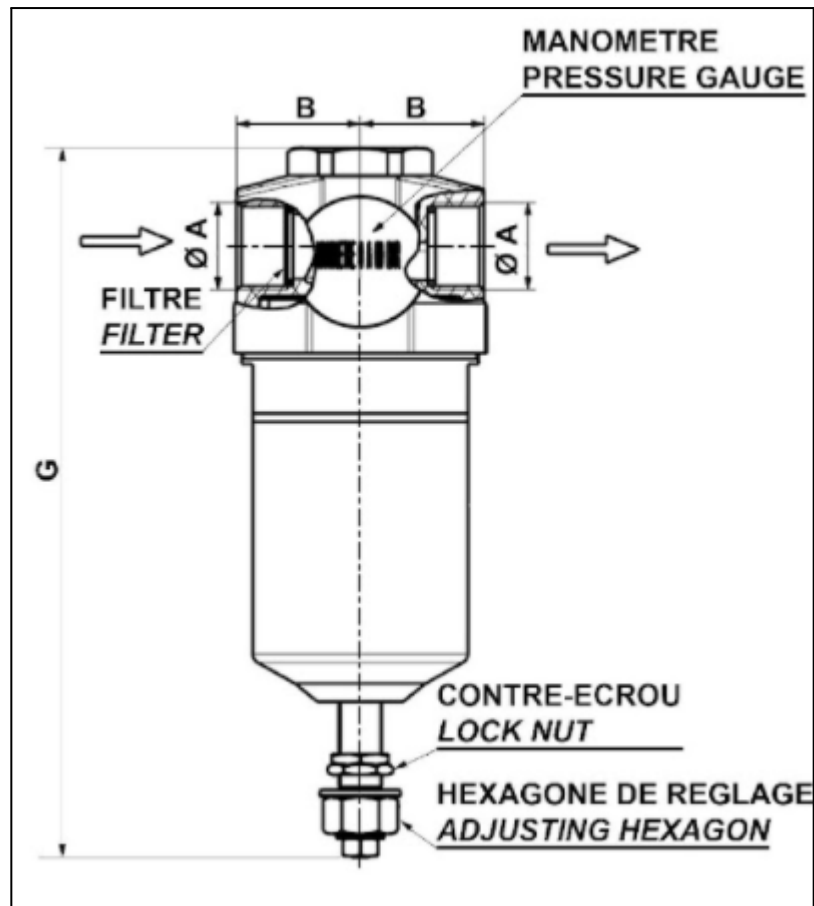

MODEL	ØA	B	C	D	E	F	G	ØH	Ø Drilling
DCn800HD	G1"	46	103	-	37,5	-	271	-	-

To contact us :

**Air Liquide Belgium :**

**tel +32 2793 3841**

**E-mail [contact.be@airliquide.com](mailto:contact.be@airliquide.com)**

**Air Liquide Luxembourg :**

**tel +352 20881137**

**E-mail [contact.lu@airliquide.com](mailto:contact.lu@airliquide.com)**

